

AFFINITY 950



■ OPERATING INSTRUCTIONS

Ergoline

Ergoline

1003519-00- / us / 04.2007

AFFINITY 950 Ultra Power Tempronic

OPERATING INSTRUCTIONS

USA

CDN

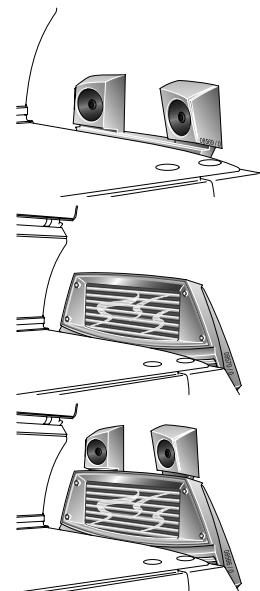
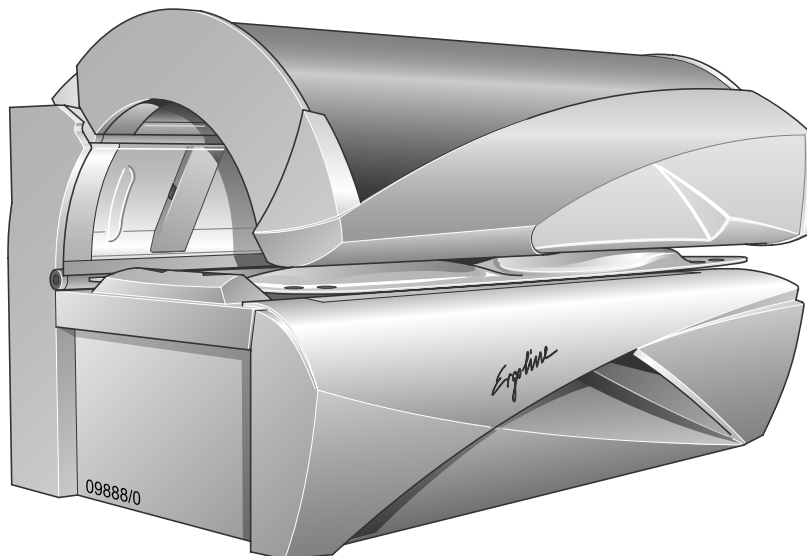

Identify your tanning device3

Table of Contents7

Identify your tanning device

For contact with Customer Services, please write down the device number of your tanning device.

--	--	--	--	--	--

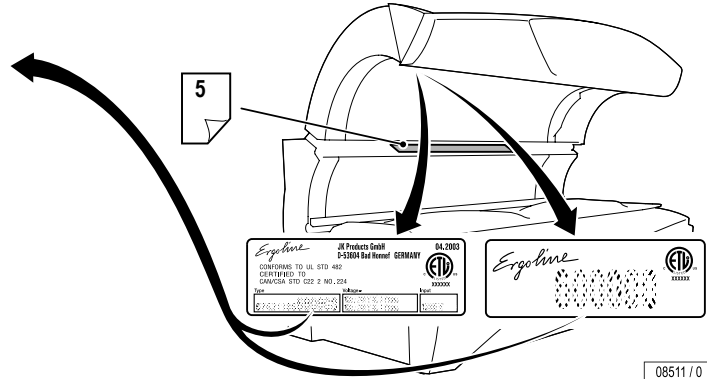
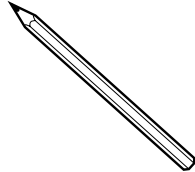

08511 / 0

Global Service USA

A Div of JK Products & Services, Inc.
#1 Walter Kratz Drive
Jonesboro, AR 72401



☎ 800-445-0624
☎ 870-935-9046

e-mail: support@jkamerica.com
<http://support.jkamerica.com>

Customer Service

Skin types

Skin types

For the recommended exposure schedule (see page 5).

Skin type I (Sensitive):

Invariably gets sunburn, accepts little natural sunlight and does not tan.

Skin type II (Fair):

This is the individual that usually burns easily and severely, tans minimally or lightly and peels.

Skin type III (Average):

Often referred to as "Average" complexion, burns moderately and tans about average.

Skin type IV (Brown):

This individual burns minimally, tans easily and above average with each exposure.

Skin type V (Dark Brown):

This individual's system rarely burns, tans easily and substantially.

Tanning times

DANGER ULTRAVIOLET RADIATION		Recommended Exposure Schedule					
Follow instructions. Avoid over-exposure as with natural sunlight. Over-exposure can cause eye and skin injury and allergic reactions. Repeated exposure may cause premature aging of the skin and skin cancer.		Week 1	Week 2	Week 3	Week 4	Weekly	
		1st - 3rd Treatments	4th - 6th Treatments	7th - 10th Treatments	11th - 15th Treatments	Subsequent Treatments	
I - Sensitive		NOT ADVISED	NOT ADVISED	NOT ADVISED	NOT ADVISED	NOT ADVISED	
II - Fair	2 Min.	5 Min.	8 Min.	10 Min.	12 Min.	12 Min.	
III - Average	2 Min.	5 Min.	8 Min.	10 Min.	12 Min.	12 Min.	
IV - Brown	2 Min.	7 Min.	10 Min.	12 Min.	12 Min.	12 Min.	
V - Dark Brown	2 Min.	7 Min.	10 Min.	12 Min.	12 Min.	12 Min.	

Maximum Tanning Time is 12 Minutes

WEAR PROTECTIVE EYEWEAR! Failure to do so may result in severe burns or long term injury to the eyes.

Certain medications or cosmetics may increase your sensitivity to the ultraviolet radiation. Consult a physician before using sunlamps if you are using medication, have a history of skin problems or believe yourself to be especially sensitive to sunlight. If you do not tan in the sun, you are unlikely to tan from the use of this product.

This unit utilizes UVA lamps. Replace only with Ergoline VHP 12 PREMIUM 160W Turbo Power, Ergoline VHP 25W Power (shoulder-/ neck-tanner) and Ergoline ultra 520W C12645 (high pressure) or recognized equivalents. To obtain recommended exposure at a minimum distance of 1/2" (13mm) measured with a standard ruler, lie on acrylic surface of lounge and lower canopy. Canopy will stop at the correct distance from lounge acrylic surface.

Warning: The use of any other position may result in overexposure!

Tanning can begin on a regular basis. An appearance of tanning normally appears after a few exposures and maximizes after four (4) weeks of exposure following the recommended exposure schedule for skin type. In order to provide for maintenance of a tan a maximum of two (2) weekly 12 minute sessions is recommended from the fifth week onward.

Do not tan more than once in a 24 hour period.

Use protective eyewear (Part No. Schmerler 2255 Red or recognized equivalents) when equipment is on. Read and follow instruction booklet before using this product. To avoid electrical shock during maintenance disconnect power from unit.

Part No: 801642a



Note:
Description of skin types see
Page 4.

10000 / 0

"This product is in conformity with performance standards for sunlamp products under CFR21 Part 1040."

Foreword

Dear Customer,

The Ergoline device you have purchased is a technically advanced and powerful product. Your device was manufactured with the greatest care and precision. It went through numerous quality and safety checks in order to guarantee trouble-free, safe operation. Nonetheless, you can also make a significant contribution to your long-term satisfaction with your device. Following the tips and instructions in the instruction manual will ensure you enjoyment and pleasure with your device.

If you have any questions, we are always available to answer them.¹⁾

Yours sincerely

JK-Products, Inc.

- Read and observe the information in this instruction manual. This will enable you to prevent accidents and provide you with a reliable device ready for use.
- Always observe current legal and other regulations and legal requirements as well as the applicable environmental protection regulations.



Note:

We reserve the right to make technical changes to the illustrations and specifications in this instruction manual.

Reprinting and reproduction, in whole or in part, of this manual is only permitted with our previous written approval and with the source specified.

1) ☎ (800) 643 0086

Table of Contents

Skin types	4	Operating instructions	23
Tanning times	5	Operation: overview	Fold-out page 24
Important safety notes and information	9	Accessories	26
Safety notices	9	Tanning	27
Intended use	10	To interrupt tanning session	28
Obligations of the studio operator	10	Settings during start-up	28
Instructions pertaining to a risk of fire, electric shock, or injury	11	Running time of accent lights	29
Instructions pertaining to a risk of damage to the machine	13	IR function	29
Meaning of symbols	14	Regulating facial tanners	30
Guidelines	17	Regulating body tanners	33
Export	17	Regulating Temptronic	35
Equipment	17	Regulating body cooling	38
Accessories	17	Regulating facial cooling	40
Product information	18	Voice Guide ¹⁾	42
Maintenance and care	19	INFO text ¹⁾	44
Cleaning	20	Selecting music channel	46
Environmental protection information	21	Adjusting volume	48
Use the sunbed – but use it properly!	22		

1) optional

Table of Contents

Technical Data	50	Presettings	88
Maintenance instructions	53	Changing presettings with the control panel	88
Power Off device and secure against being switched on again.	53	Changing presettings with a hand-held unit	90
Maintenance: overview	Fold-out page 54	Troubleshooting	93
Cleaning intervals	56	Index	97
Maintenance intervals, installed lamps and order numbers.	57	JK-Products, Inc. – Limited Warranty	99
Relamping/maintenance instructions	61	Timer operation – see manual “Intellitan Remote Timer”, Order no. 801129-..	
Cleaning/replacing UV low-pressure lamps in sunbed base	62		
Cleaning/replacing UV low-pressure lamps in shoulder tanner.	64		
Cleaning/replacing UV high-pressure lamps and filter panels in the side section	66		
Cleaning/replacing UV high-pressure lamps and filter panels in the canopy	69		
Cleaning/replacing interior lighting	73		
Cleaning/replacing accent light in the canopy	75		
Cleaning/replacing accent light in the frontpanel	77		
Option: Cleaning/replacing ambient lights	79		
Cleaning filters in the sunbed base	80		
Cleaning filter mats in the canopy	82		
Cleaning filter mats in the shoulder tanner	83		
Temptronic/Air Condition: cleaning/replacing filter and filter mat, emptying condensate container	85		

Important safety notes and information

Safety notices

Description of warning signs

Danger notices, damage to persons:



DANGER!

Type and source of danger, e.g. “DANGER – High voltage!”

Description of the consequences, e.g. “You can be killed or injured by an electric shock!”

Countermeasures:

- Disconnect device from power supply before opening.
- Do not reach into the inside with the device switched on.

Warning notices, damage to persons:



WARNING!

Type and source of danger, e.g. “Warning – hot surface!”

Description of the consequences, e.g. “You can burn your hand (skin, face)!”

Countermeasures:

- Do not touch hot parts and nearby surfaces.
- Wait until hot parts and surfaces have cooled down.

Caution notices, damage to property:



Caution!

The word “Caution” with this label points out that danger for devices, materials and the environment can be expected here.

Important information:



Note:

This symbol does not identify safety notices, but states information for a better understanding of the processes.

Please read and observe ...

Intended use

The tanning device is intended exclusively for cosmetic tanning of the human skin.

- The device is meant for commercial use only, not for home use.
- This device is used for tanning one adult person at a time.
- The user wears suitable eye protection that blocks UV radiation during tanning.

Any other use shall be considered improper. The manufacturer cannot be held liable for damage or injuries resulting from this. The operator bears the sole risk for this.

The proper use also includes compliance with the manufacturer's instructions, operating and maintenance conditions. This device may only be operated, maintained and repaired by persons familiar with these tasks and who have been informed of the dangers involved.

Obligations of the studio operator

- As the operator you are responsible for informing users on possible risks during tanning.
- All danger and safety labels attached to the device must be observed! Do not remove them!
- No safety equipment (e.g. panel switch) may be removed or deactivated which can impair the safe operation of the device!
- The device may only be operated in a serviceable condition!
- The operator is bound to ensure that the equipment is handled correctly.

Instructions pertaining to a risk of fire, electric shock, or injury



DANGER!

DANGER – High voltage!

You can be killed or injured by an electric shock!

Assembly and electrical connection must comply with national and local regulations.

- The device may only be assembled, installed, upgraded or repaired by specially trained and instructed personnel.



WARNING!

WARNING – ultraviolet radiation!

Unprotected tanning may result in eye injury and eye diseases.

The unprotected eye can become inflamed on the surface, and in certain cases the retina can be damaged by excessive radiation. Cataracts can form after frequently repeated exposure to radiation.

- **Inform users to use the included protective goggles that block UV** (Order No. 84592-..).



WARNING!

WARNING – ultraviolet radiation! Follow instructions!

Failure to use protective eyewear may result in severe burns or other eye injury. If discomfort develops, discontinue use and consult a physician.

- A person who does not tan in the sun most likely will not tan from the use of this device. Persons with very sensitive skins (skin type I) must not use the unit, as with this skin type tanning is impossible without damaging the skin (e.g. sunburn).
- Individuals with acute sunburn, individuals who have had or have skin cancer, or individuals who are at increased risk of skin cancer, must not use the system.
- UV devices must not be used without taking medical advice if unexpected effects, such as itching, occur within 48 hours of the first session.
- The sunbed must never be used if a filter panel is missing or damaged, or the timer is defective!
- UV light from the sun or UV systems can cause injuries to the skin or eyes. This biological effect is dependent on the sensitivity of the individual's skin and on the type and amount of UV light.
- As with natural sunlight, overexposure can cause eye and skin injury, sunburn, and allergic reactions.

Please read and observe ...

**WARNING!**

- Repeated exposure may cause premature aging of the skin and skin cancer.
- Medications or cosmetics applied to the skin, may increase sensitivity to ultraviolet light.
- A person having a history of skin problems should consult a physician before use.

**WARNING!****WARNING – ultraviolet radiation!**

Danger of long-term consequences.

- Overexposure should be avoided.
- The elderly should not use this equipment.
- Nursing infants and small children through age 7 years may not use this device.
- The following applies to minors under the age of 18 years: Only use tanning devices in agreement with a parent or guardian, or after consulting a physician.
- While there is no immediate clinical evidence of UVA exposure and its effects upon expectant mothers, it is strongly advised that expectant mothers be discouraged from using the tanning unit.

**WARNING!****WARNING – risk of infection!**

Infections can be transferred through skin contact.

All items/equipment components, with which the user can come into contact during tanning, must be disinfected after every tanning session:

- Protective goggles
- Headrest
- Acrylic sunbed
- Handles and control panel



Note:

Occasionally, persons using the tanning device will experience a slight reddening of the skin – usually in small patches – after the second or third session. This redness is often accompanied by an itching sensation. This may be nothing more than a heat “rash” caused by heat from the lamps within the device. It is generally very limited and caused by constant contact of the skin with the acrylic surface. It should go away within approximately 24 hours and should not reappear. This rashing can be lessened or prevented by applying moisturizer lotion to the affected area after the tanning session is completed.

- Follow instructions.
- The time between the first two tanning sessions must be at least 24 hours.
- Increasing tanning also requires an extension of the exposure time (= radiation time) or after a certain degree of tanning has been achieved, a further intensification is not possible. However, the radiation time may not be extended as desired within the scope of the permissible radiation doses! Therefore, only a certain degree of final tanning dependent on the skin type can be achieved without endangering your health.
- Inform users about proper tanning.

Instructions pertaining to a risk of damage to the machine



CAUTION – danger of overheating!

Danger of overheating by obstruction of the air routing.

- Do not change, obstruct or block the air inflow and outflow area to the device or make any unauthorized changes to the device. The manufacturer shall bear no liability for damage or injuries resulting from such actions.
- Before putting a tanning device into operation, the transport pallet must be removed from under the device. Danger of overheating by obstruction of the air routing.

Please read and observe ...

Meaning of symbols

General symbols



Inform Customer Services



Ergoline key



Do not touch, hot surface!



Suction cup



Low-pressure lamp(s)



UV low-pressure lamp(s)



Starter for low-pressure lamp(s)



UV high-pressure lamp(s)



Filter panels



Cleaning and disinfectant agents



Part/item number (for orders)

Operation



Display of tanning time



Display of run-on time (fan run-on)



Fault display (example),
see separate manual



Display of Info Track 1 (from 1-17)



Display of Music Channel 1 (Channel 1)
Factory setting: 1 channel
Customer service can set up to 7 channels

Please read and observe ...

	Display when adjusting volume
	Description
	Accent lights
	Press button
	Press button for 2 seconds
	Duration: 3 minutes
	Loudspeaker
	Headphone connection
Technical Data	

Maintenance		
	Caution, safety switch!	
	Unscrew/release screw	
	Tighten/lock screw	
	Cleaning	
	Replacing	
	Clean or replace depending on soiling	
	Draining	
	Air condition / Temptronic	

Please read and observe ...



Visual inspection



Filter/filter mat



Filter and filter mats must not be damp.



Continuation of work steps on next page



End of work step

Presettings



Troubleshooting



Guidelines

This device was built conforming to UL STD 482, and is certified to CAN/CSA STD C22.2 2 No. 224.

Export

We would like to point out that these devices are exclusively intended for use in the USA and Canada and may not be exported to other countries and operated there! The manufacturer assumes no liability whatsoever in the event of non-compliance! We explicitly emphasize that high liability risks may occur for the exporter and/or the operator in the event of non-compliance.

Equipment

The equipment of the devices differs depending on the model.

In this instruction manual all standard and optional components/functions are taken into account which must be observed during operation and/or when performing maintenance.

The control panel is also affected by the differing equipment: Only those buttons are visible that can be operated, i.e. the corresponding function must be part of the equipment of the device.

Accessories

Some accessory parts are taken into account in the maintenance schedule beginning on Page 54, however this does not automatically mean that your device is provided with this equipment.

An overview of the possible accessories is provided in the sales documentation and the planning manual. See page 26 for a selection of these.

Please read and observe ...

Product information

Acrylic glass panels

The acrylic glass panels for the tanning devices are produced of acrylic glass developed especially for this application. The acrylics used are characterized by a particularly high UV permeability and resistance, as well as an easy-care, hygienic surface that is gentle to the skin.

The acrylic glass panels are formed to their shapes for the specific devices in a technically complex production process. Despite state-of-the-art production know-how, the presence of minor spots, air bubbles or streaks in the acrylic panels is unavoidable. In addition, microfine hairline cracks can occur on the bed surface during operation.

These occurrences are material-dependent and are unavoidable in processing, however have no significant effect on the use or value and can therefore not be recognized as defects.



CAUTION!

Cosmetics or sun screen products must be removed prior to using the sunbed as they can cause damage (e.g. fine cracks on the surface) when used continuously.

Maintenance and care



DANGER!

Extreme danger! High voltage!

During maintenance work there is a risk of touching live parts and receiving a fatal electric shock.

- Disconnect device from power supply before opening – also see Page 53.
- Do not reach behind covers and do not open the device with the device switched on.
- Refit any safety devices (e.g. switches) after the work has been completed.

Maintenance and care play a major role in deciding whether the device meets the requirements placed on it in a satisfactory manner. The compliance with the specified maintenance intervals and the careful conducting of the maintenance and care work are therefore absolutely necessary – see Page 54.

The current operating hours of the parts requiring maintenance can be displayed in the Presetting mode – see Page 88 ff.



CAUTION!

Only use **genuine** spare parts of the same type!

The use of other parts may limit or void your manufacturer's warranty!

Any liability is excluded in case of damage or injury proven to be the result of the use of non-genuine spare parts.

Cleaning

Acrylic glass surfaces



CAUTION!

Do not rub with a dry cloth – danger of scratching!

For fast, hygienic proper cleaning of acrylic glass surfaces, use a specially developed fast disinfectant cleaner.

Other cleaning agents, especially concentrated disinfectants or solvents (e. g. Lysoform, ethyl alcohol or other liquids containing alcohol) must never be used for cleaning.

Failure to observe this voids all warranty claims.

Plastic surfaces

For cleaning the other plastic surfaces, it is best to use warm water and a leather cloth. Never use aggressive cleaning agents containing alcohol or essential oils. These may lead, in the long run, to damage not covered by the warranty.

During cleaning, a slight discoloration of the leather cloth by the rubber seals must be expected for production-related reasons.



Note:

Prevent damage to plastic surfaces. Remove rings, watches, bracelets etc. before the start of cleaning work.

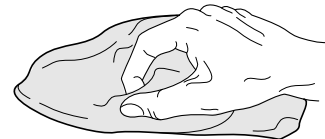
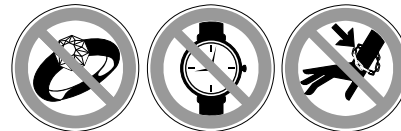

02756 / 0

Please read and observe ...

Environmental protection information

Environmental Declaration – The JK Corporate Group

The JK corporate group is subject to the strict regulations of EC Directive 761/2001 and the ISO 14001 standard, and undergoes regular internal and external environment audits performed by trained auditors.

Environmental regulations – disposal of lamps

UV low-pressure lamps and UV high-pressure lamps contain fluorescent materials and other waste containing mercury.

According to the national waste disposal laws and in accordance with the municipal waste regulations, proof must be provided of the proper disposal of UV lamps.

Your local environmental agency will be happy to assist you with the disposal of UV lamps.

Packaging

All packaging consists of 100 % recyclable materials.

Disposal of recyclable materials

The device has been produced of recyclable materials. When being scrapped later, the device must be disposed of properly. Sun Ergoline will provide you with information on the content or potential hazards of the materials used.

Please read and observe ...

Use the sunbed – but use it properly!

A few things need to be noted to get maximum enjoyment from a sunbed. Here are some answers to some frequently asked questions.

Make-up on the sunbed?

Please remove make-up or don't use make-up while tanning. Clean skin absorbs UV light better.

A wide variety of ingredients are found in cosmetics. Again, whether these are emulsifiers, greases, or so-called scents – in conjunction with UV radiation, these can cause allergic reactions of the skin.

Accordingly, a must before using a sunbed is: Remove all make-up. This is essential. Make-up clogs the pores in the face. The UV light from a sunbed re-opens these clogged pores so that not only does the light penetrate the skin, but also the allergenic components of the make-up.

A further negative consequence of make-up is that the appearance of the skin deteriorates irreversibly over a period of time. However good a decent make-up might be – in conjunction with UV light, it causes more harm than good. Therefore: Remove all make-up before a session on your sunbed – it will be much better applied afterwards.

Showering after leaving the sunbed?

The browning is in the skin, not on it. Therefore you cannot wash it off. Treat your skin to a moisturizing cream after showering.

Are medications and the sunbed compatible?

It is known that some medications increase the skin's sensitivity to UV light. This probability is particularly high with antibiotics, sulphonamides, psychiatric drugs, tranquilizers, anti-diabetes treatments and diuretics. Sun creams which contain psorale or kumarin also increase skin sensitivity. If you are in any doubt, first ask your doctor - then you can enjoy the sun at no risk.

Contact lenses on the sunbed?

The answer is: Yes! Like any other sunbed user, contact lens wearers should also wear special protective goggles which protect the eyes against UV radiation. To guarantee better protection, wearers of spectacles and contact lenses can ask their optician for exchange contact lenses with UV protection. The UV-A and UV-B filters built into exchange contact lenses will protect the cornea and the internal parts of the eye against almost 100% of the energy in UV radiation.

This will benefit sunbed users not only in the open air, but on the sunbed itself. For more information, ask your optician or optometrist.

Operation

Mandatory reading

Always read and follow all instructions for proper usage prior to allow anybody using a tanning device. The operating instructions included with this device must always be followed to prevent possible injuries or to reduce them to a minimum.

Inform users

- to use provided UV-blocking protective eyewear whenever the equipment is energized.
- to follow the exposure schedule in accordance with their skin type. Failure to do so may result in overexposure.

A tanning system is not a toy. You cannot vary the strength of the lamps in your unit.

Should you have any questions regarding the proper use of your tanning system, contact Global Service USA at:

(800 445 0624

7:00 a.m. to 7:00 p.m. (CT)



WARNING!

Warning – ultraviolet radiation!

Danger of skin injuries and skin diseases!

- The sunbed must never be used when a filter panel is missing or damaged, or the timer is defective!



Note:

When describing the operation, the tanning device is often shown with the canopy open. During tanning the canopy must always be closed.

Proper operation is not possible with the canopy open.



Operation



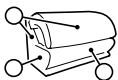

Operation

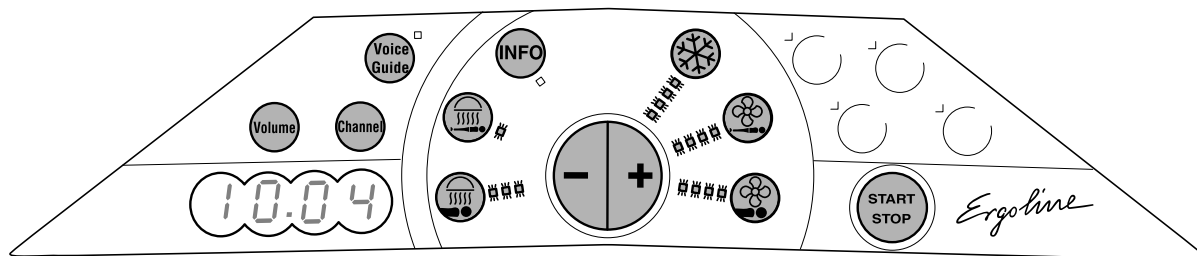

09999 / 0



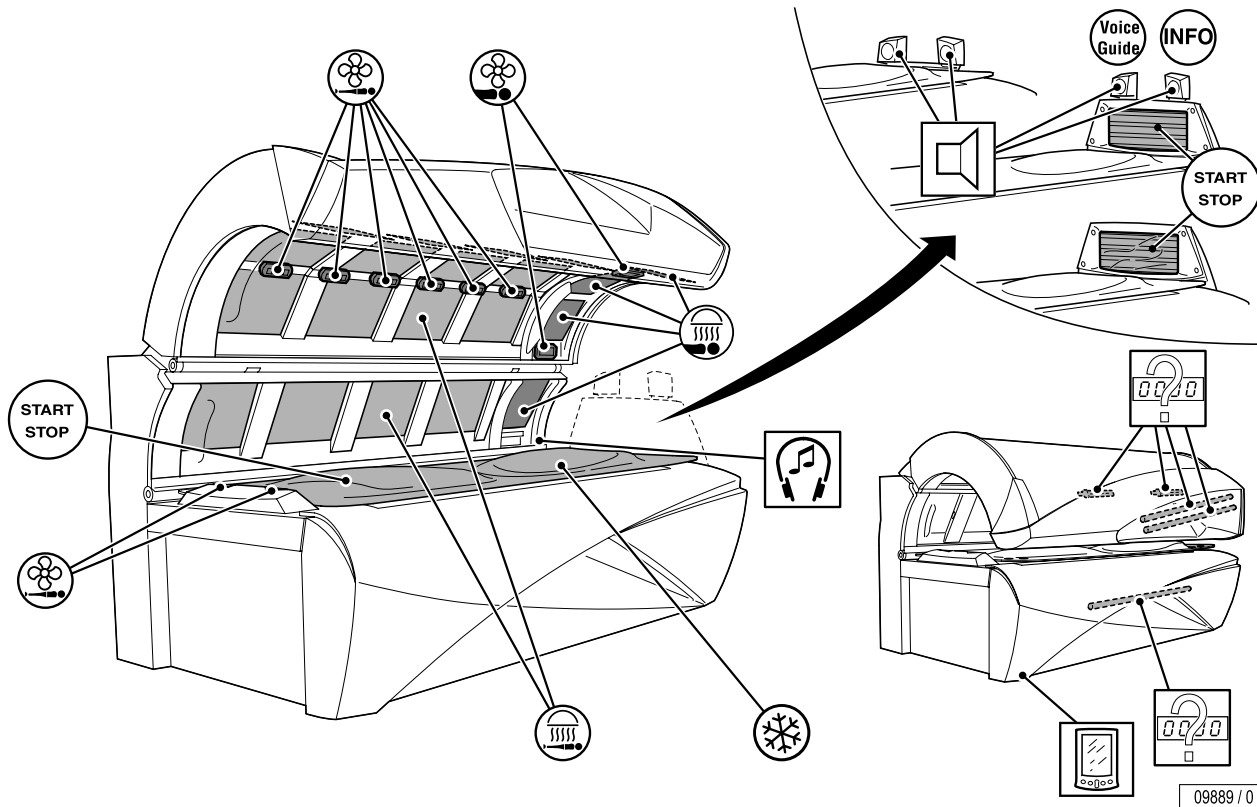
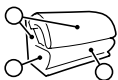

Operation

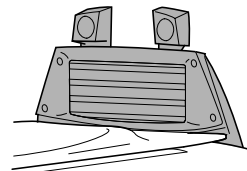
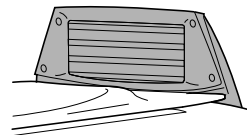
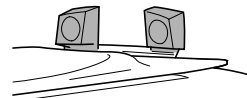
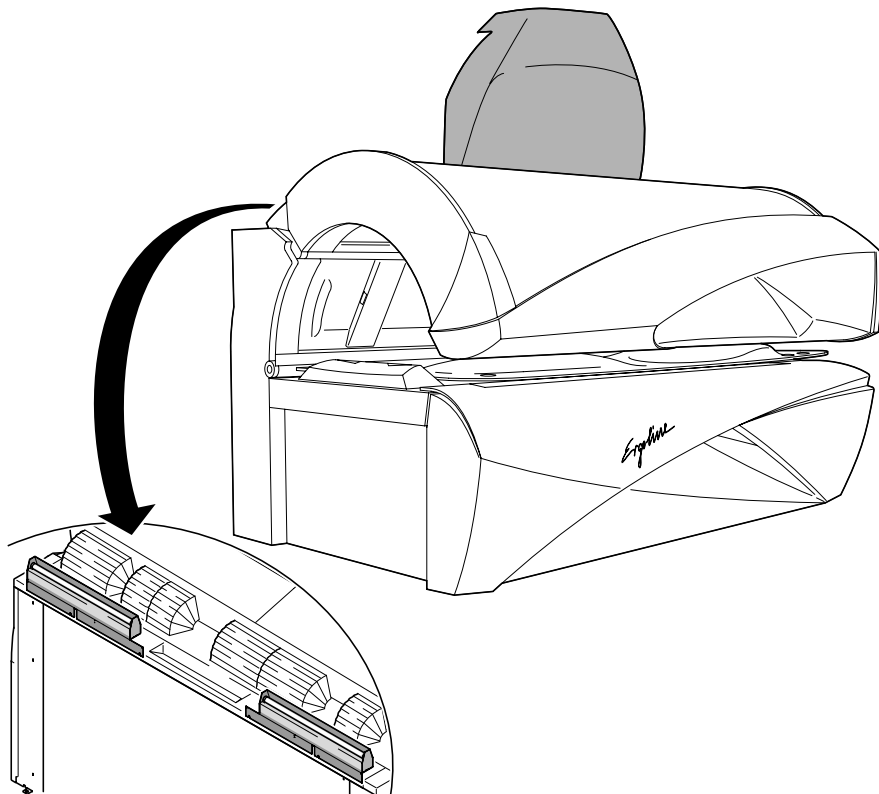

09890 / 0





Tanning

Start of tanning

The device is started automatically with an internal or external timer.



Note:

Timer instructions: see separate manual¹⁾.

Preparation time

Before the UV lamps turn on, you have a few minutes to prepare yourself. During the preparation time you can switch on the UV lamps at any time by pressing the START/STOP button.

- Remove your clothes and all jewelry.
- Remove make-up and other cosmetics.
- Remove glasses. Contact lenses can be worn under the protective goggles.
- Put on the protective goggles.
- Lie down on the bed surface.
- Close the canopy.
- Press the START/STOP button.

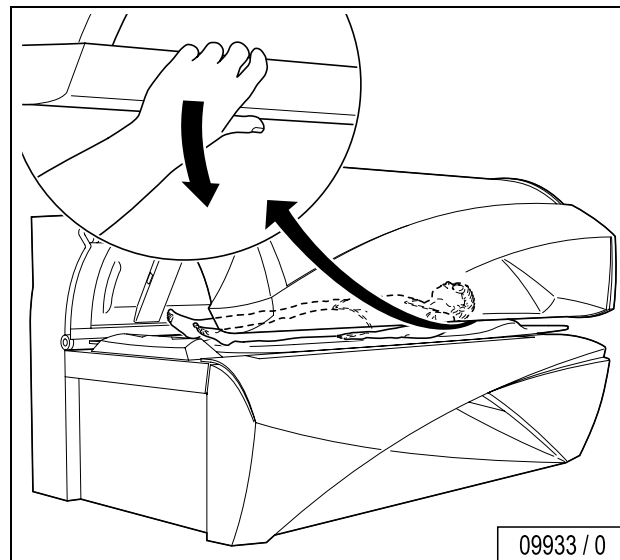

Operation

1) Order no 801129-..



Interrupt or end tanning session

The tanning session ends automatically after the preset time has run down. The internal fan continues to run for approx. three (3) minutes to sufficiently cool the device.

- To interrupt a tanning session, press button START/STOP anytime during a session.
- Press START/STOP again to restart the lamps.

Settings during start-up

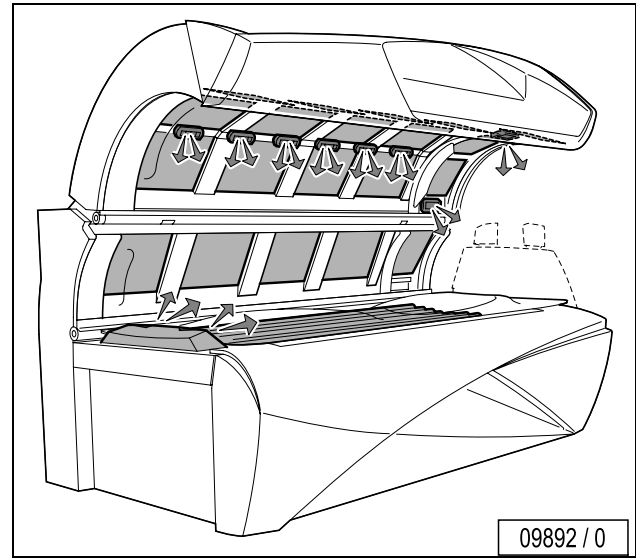

optional:

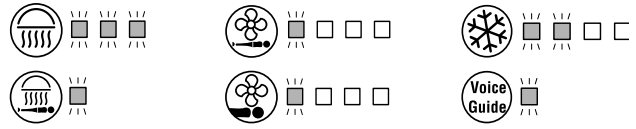



Running time of accent lighting

The accent lights are automatically switched on at the end of the tanning session after the set operating time and are switched off again at the beginning of the next tanning session. The running time of the accent lights in the Standby mode can be changed with the presettings – see from Page 88 on.

Stand-by

1

09917 / 0

2

09918 / 0

IR Function

08585 / 0

see Presettings

Operation





Regulating facial tanners



Switching the facial tanners OFF:

- Press button  for two (2) seconds.

Switching the facial tanners on again:

- Press button . It takes approx. one (1) minute until the facial tanners reach their full output.

Adjusting the intensity:

- Press button .
- While the button  flashes, press + or - to adjust the intensity of the facial tanners.

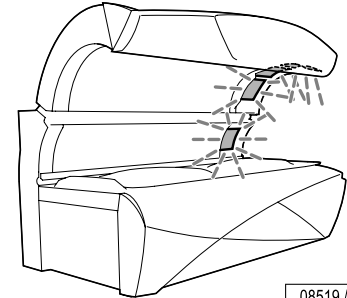

08519 / 0

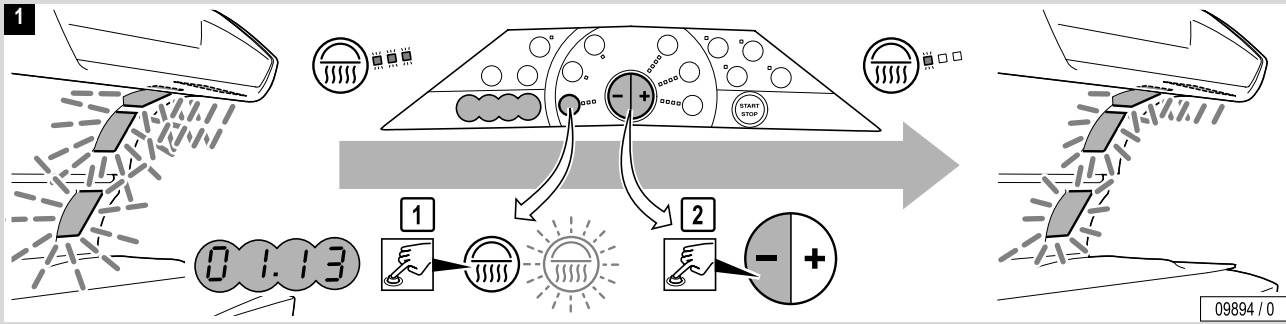

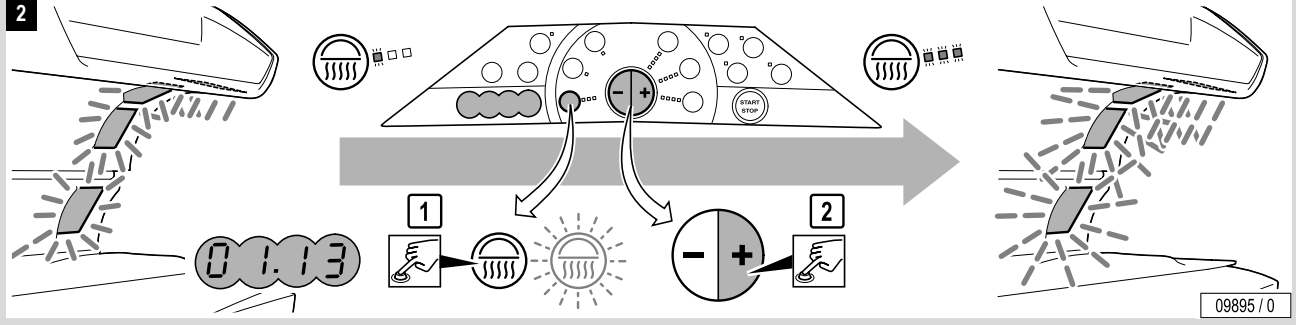

STOP: Press for two (2) seconds.

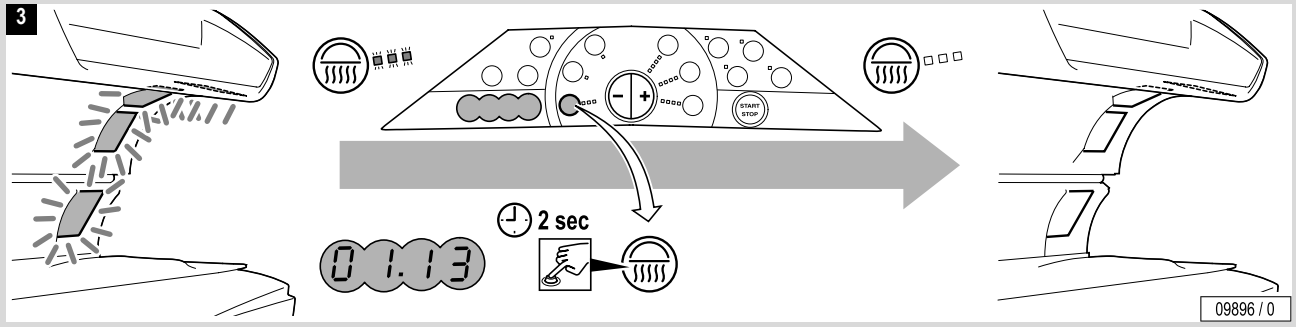



START

4

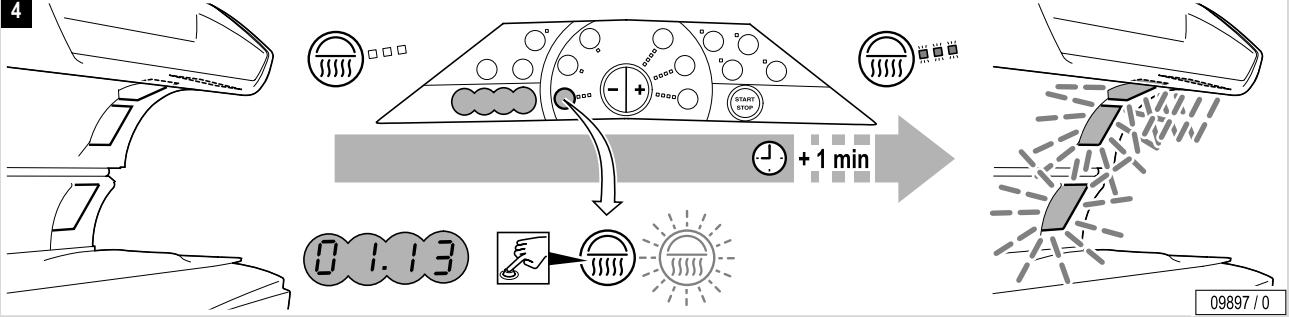

09897 / 0



Operation





Regulating body tanners

Adjusting the intensity:

- Press button .
- While the button  flashes, press + or - to adjust the intensity of the body tanners.

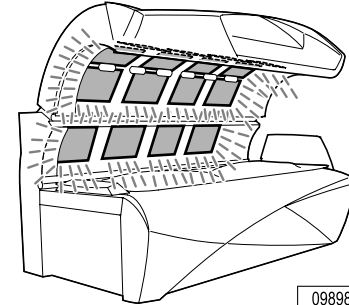

09898 / 0

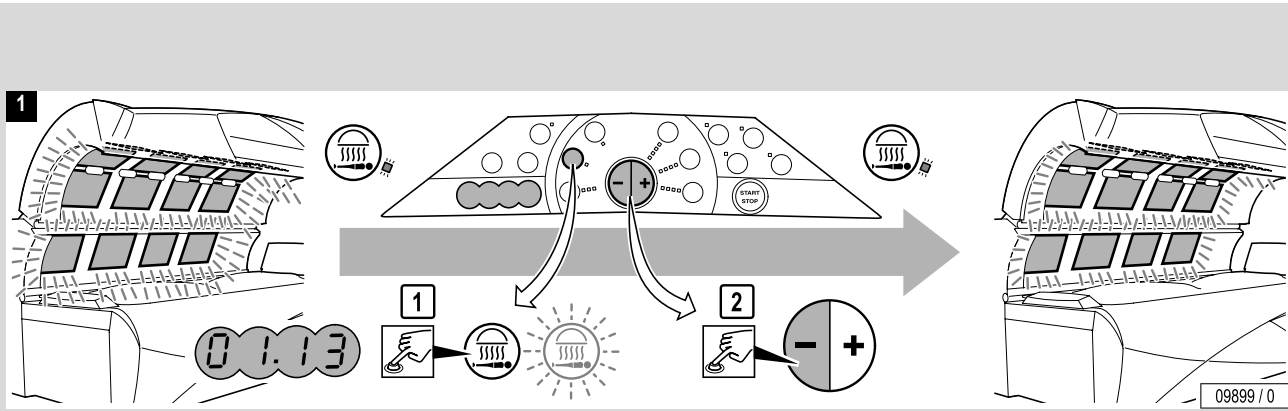



2

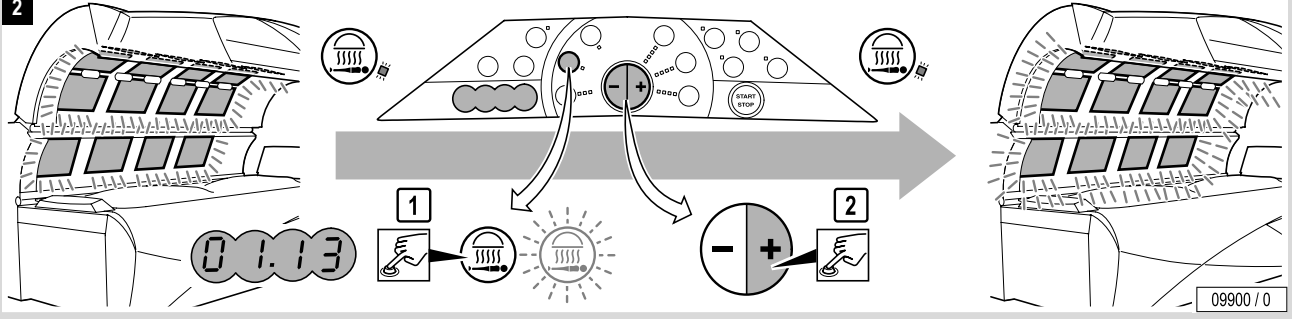



Temptronic – Adjust coolness

During start-up the lightlevel of 8 is active.

- Press button  (Temptronic).

While the button flashes, press the plus or minus button to change the cooling intensity.

Switching Temptronic OFF:

- Press button  for 2 seconds.

Switching Temptronic on again:

- Press button  again. It takes approx. 3 minutes until the cooling effect of the air condition is reestablished.



Note:

If the automatic climate control (Temptronic) fails, the sunbed will be cooled without any control. In this case, the user can only switch the cooling on and off.

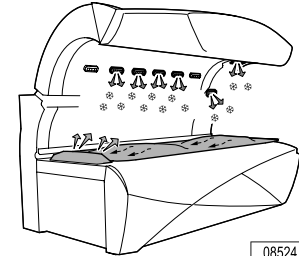

08524 / 0



Operation

Lower temperature

1

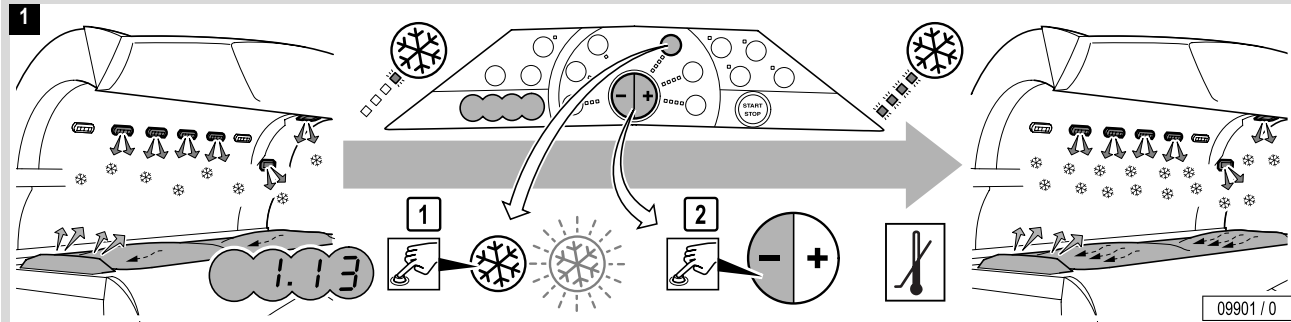

09901 / 0



Higher temperature

2

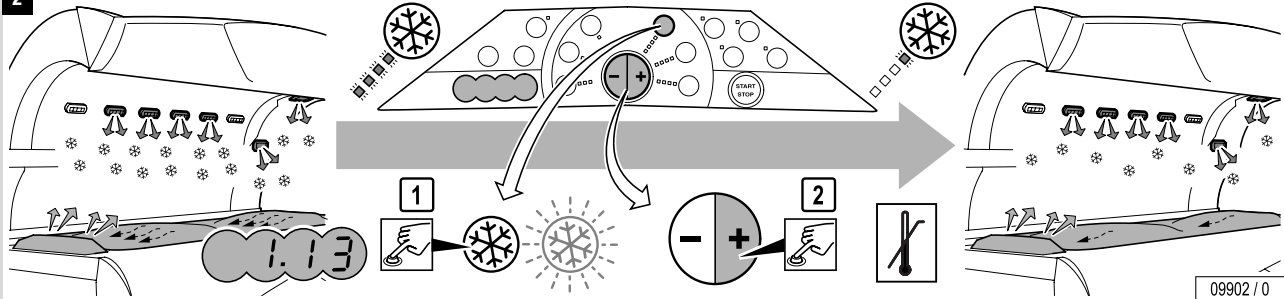

STOP

3

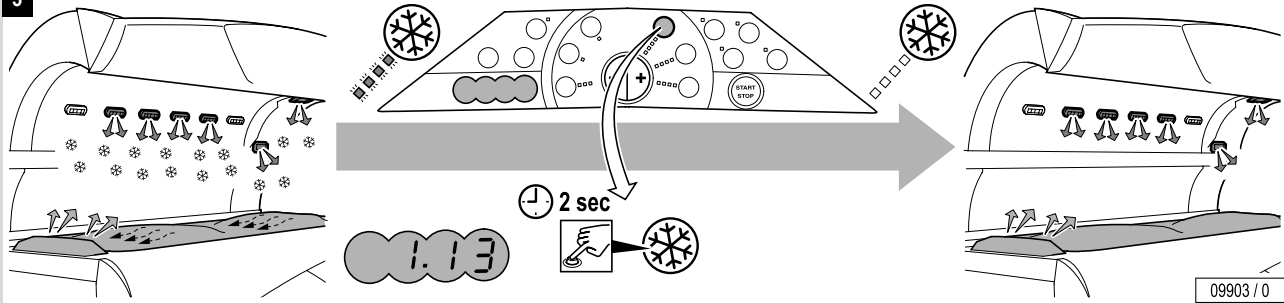



START

4

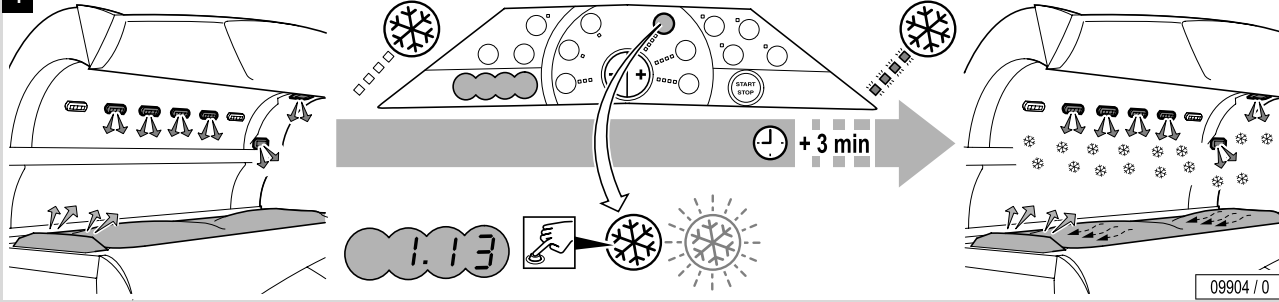

Operation





Surround cooling body ventilator – Adjust speed

- Press button .
- While the button flashes, press the plus or minus button to change the intensity of the air stream.

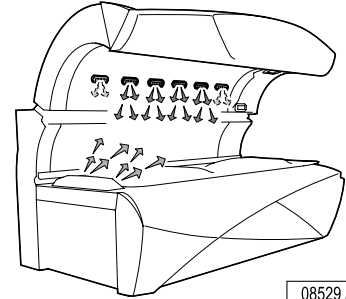

08529 / 0

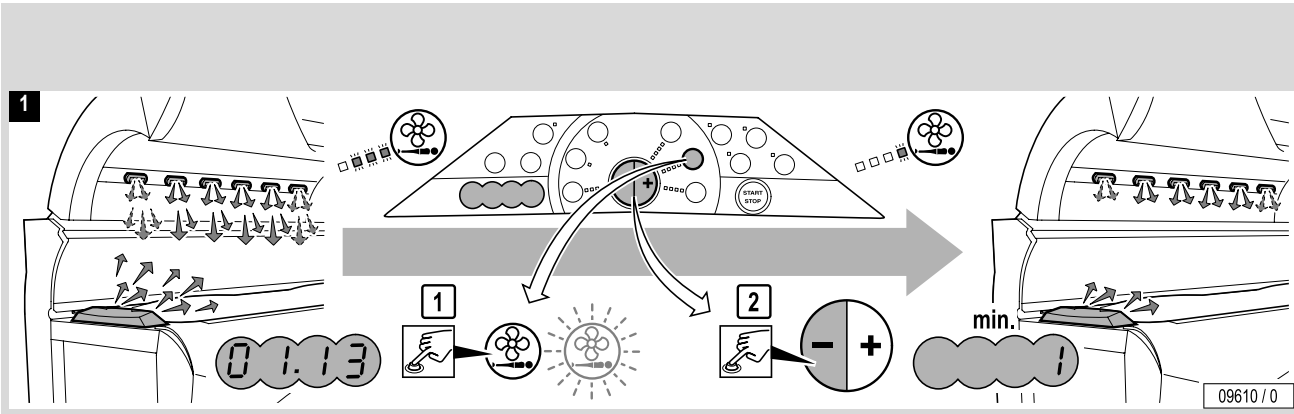

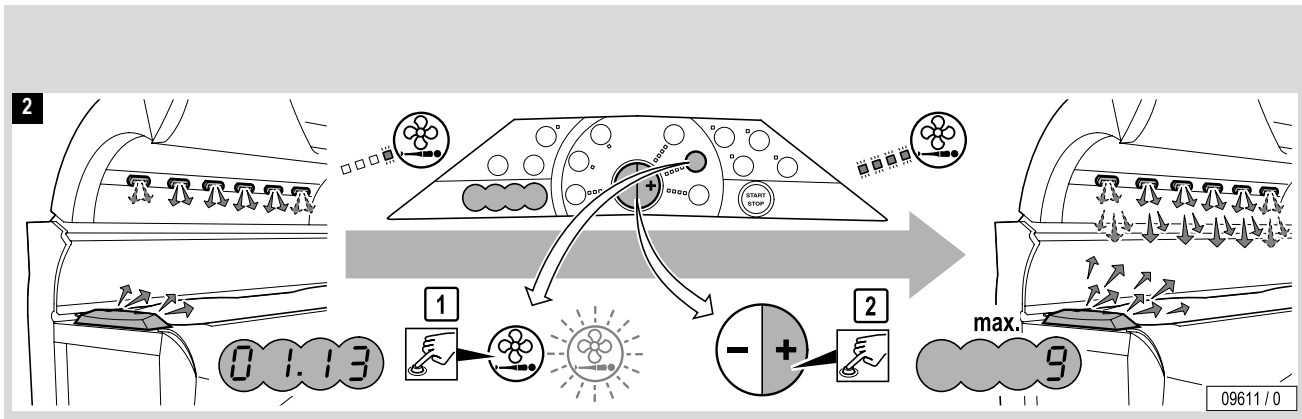



Surround cooling head nozzles – Adjust speed

- Press button .
- While the button flashes, press the plus or minus button to change the intensity of the air stream.

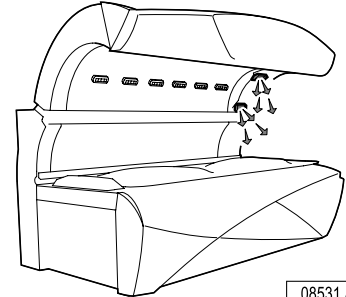

08531 / 0

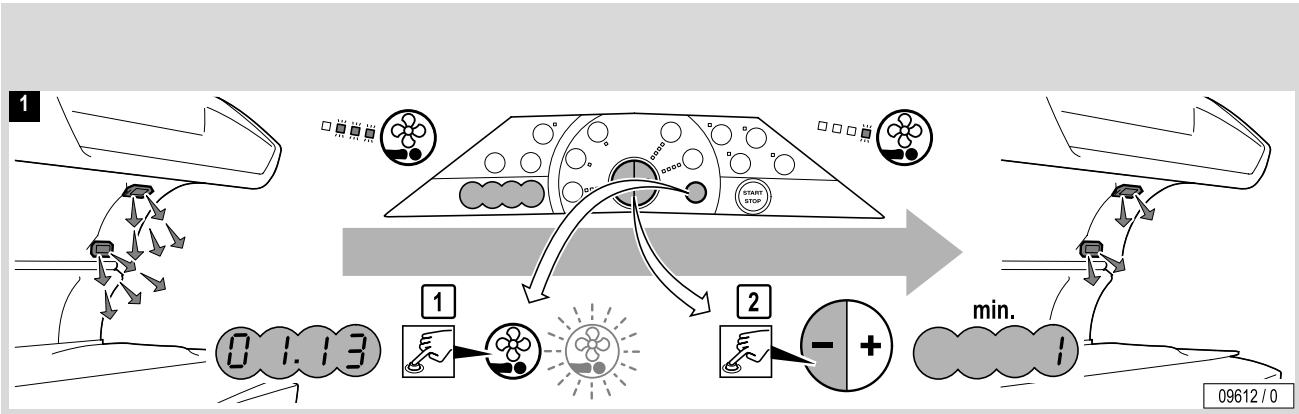

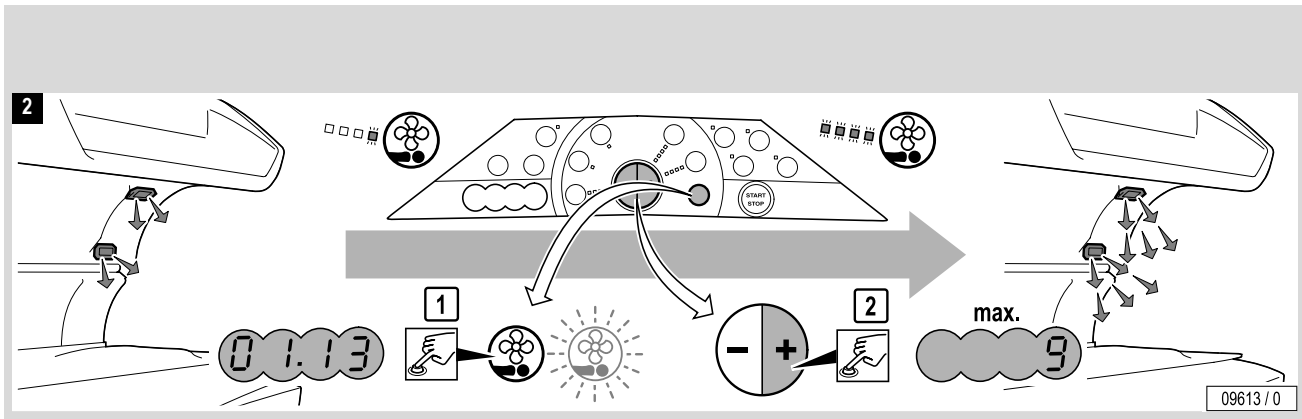

Operation



Voice Guide

Voice Guide gives acoustic guidance when operating the device and is only available in conjunction with the audio system (with or without shoulder tanner).

Voice Guide is activated by default during both stand-by and a tanning session.

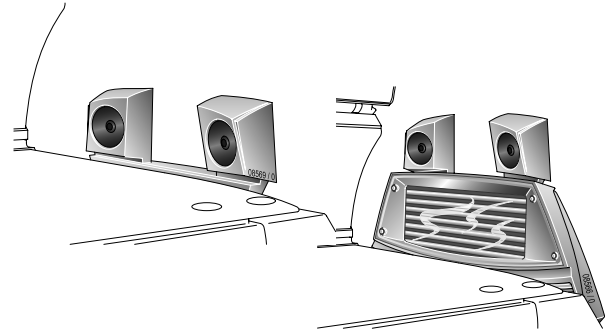

Operation

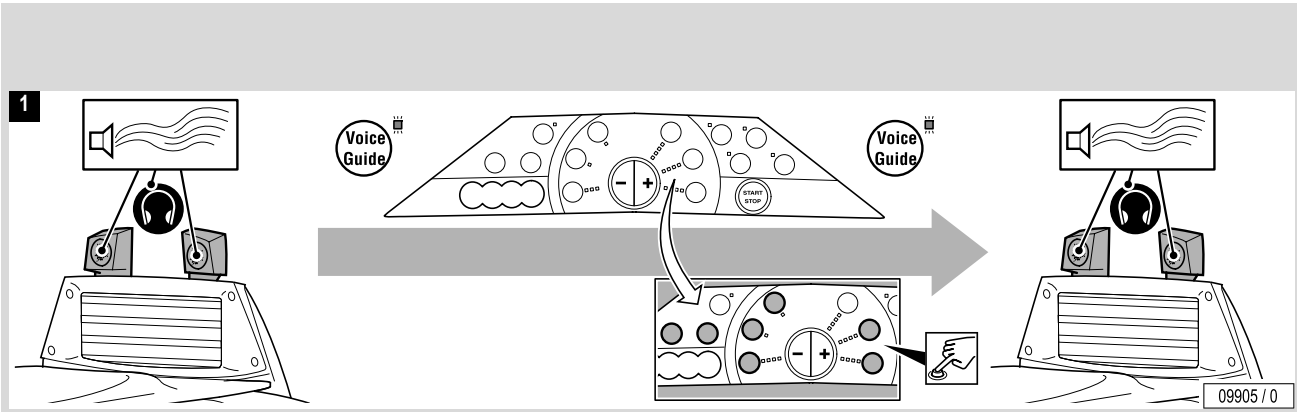

STOP

2

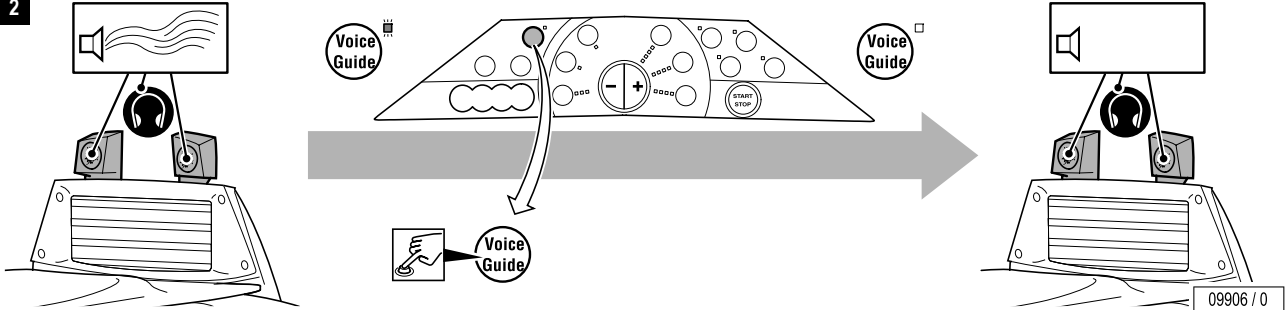

START

3

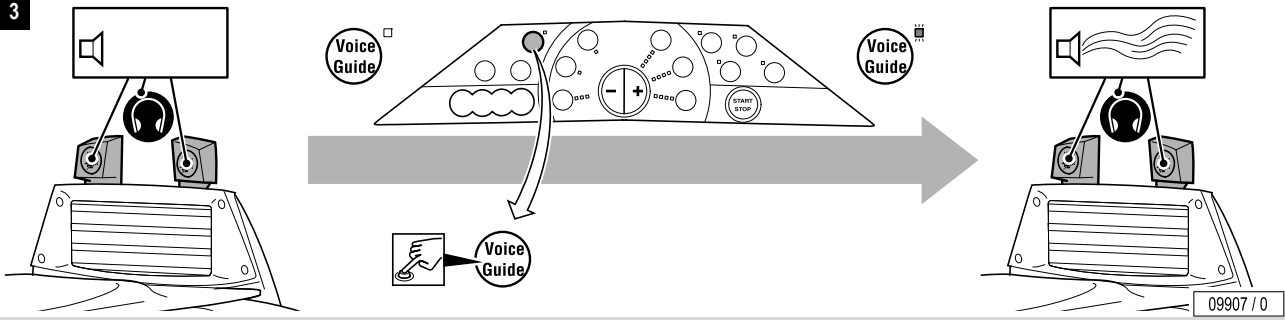

Listening to Info texts

General information about the sunbed.

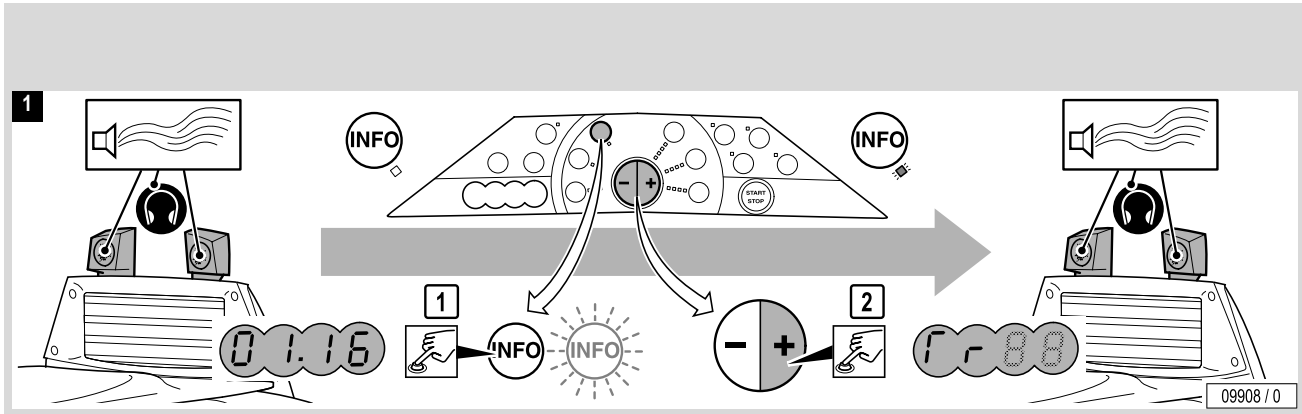
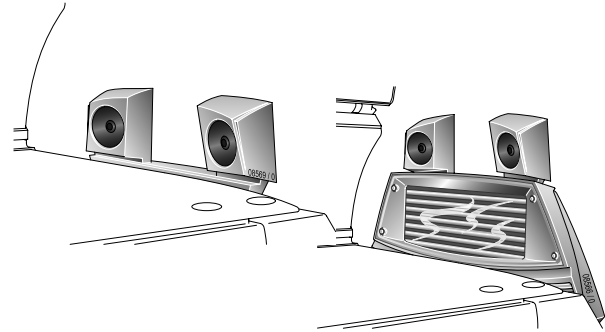

2

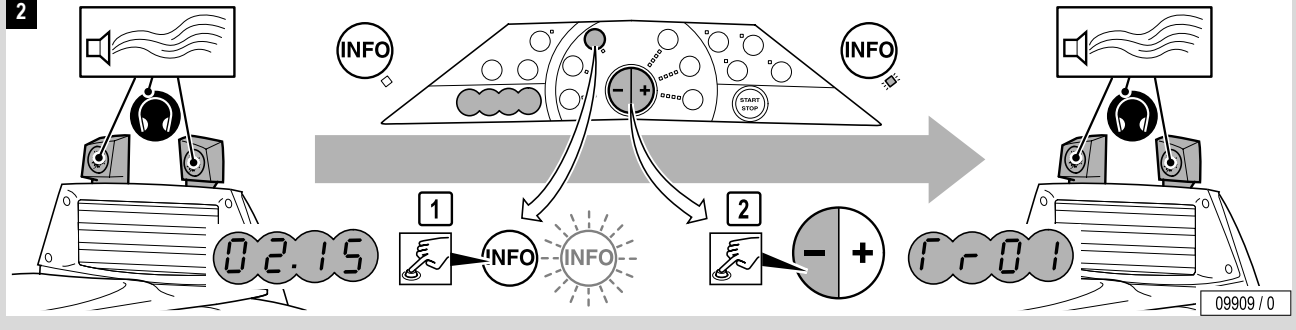



Selecting music channel

- Press button .
- While the button flashes, press the plus or minus button to change the channel.

CH.00 means: no Channel selected, there is no sound, music is "OFF".

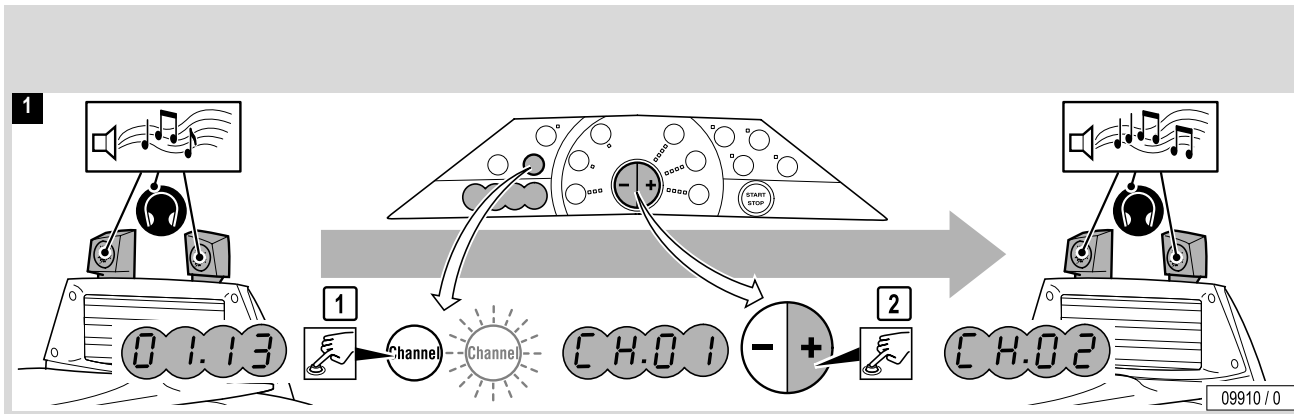
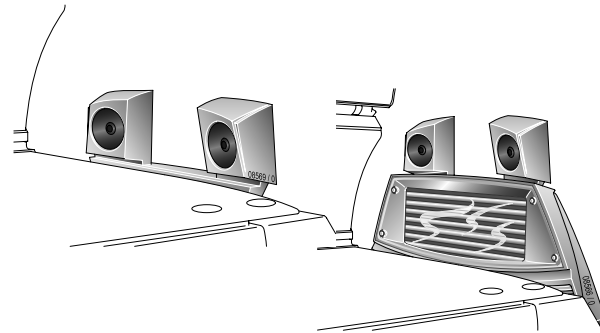



STOP

2

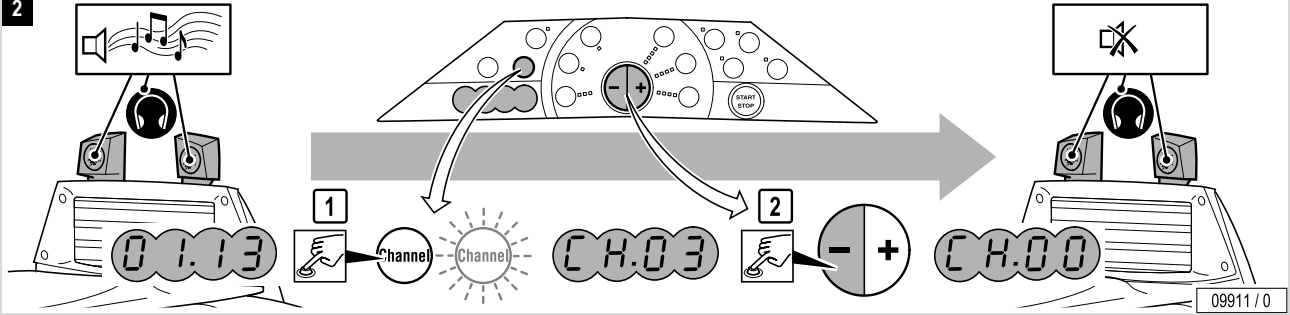

Operation

START

3

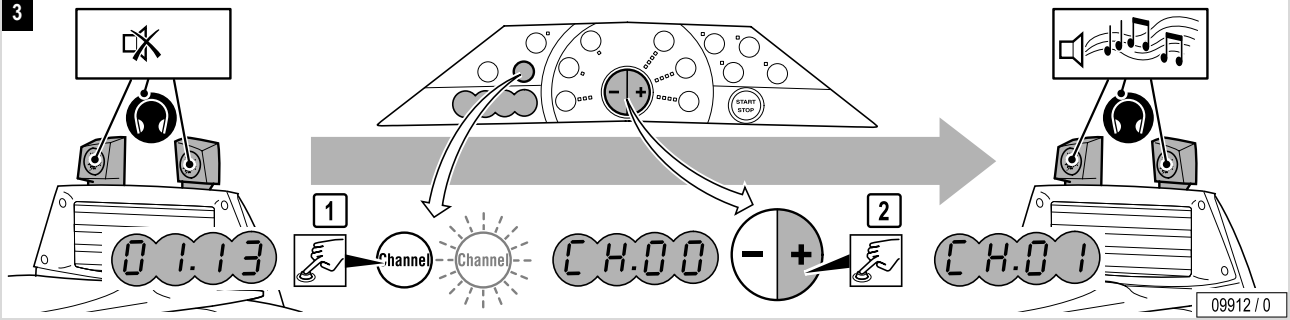



Adjusting volume

- Press button .
- While the button flashes, press the plus or minus button to change the volume.

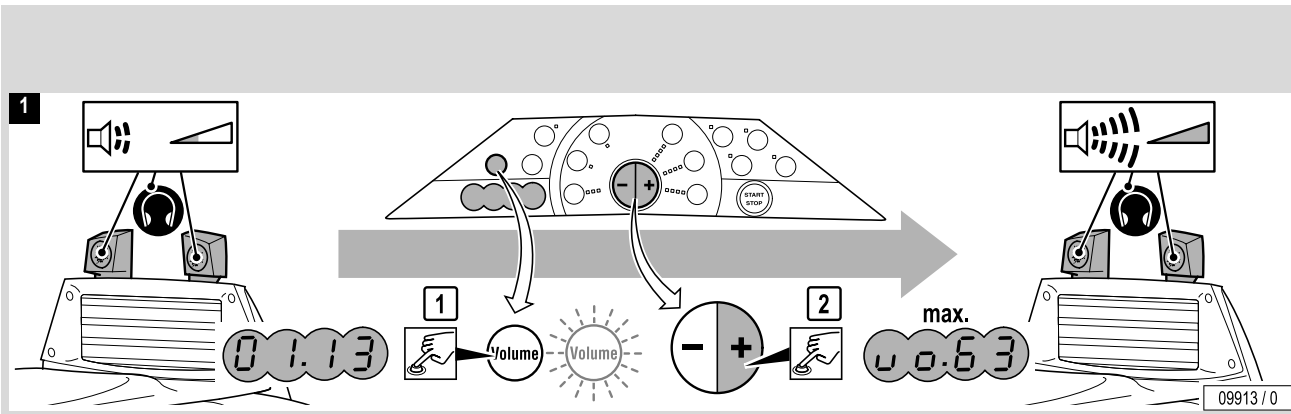
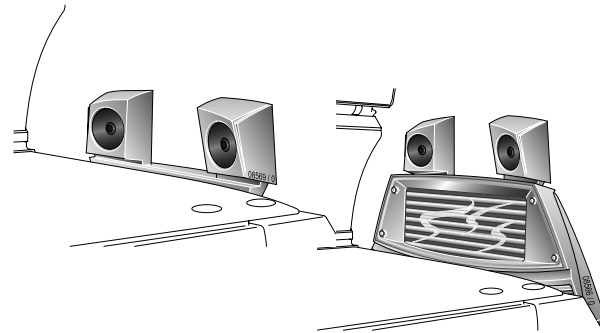

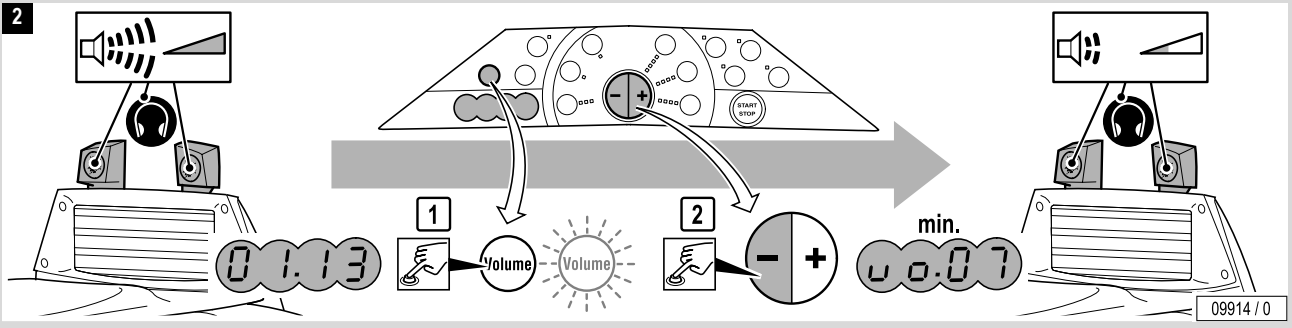

Operation





Technical data

Technical
Data

Model:	Ergoline AFFINITY 950 Ultra Power Temptronic
Rated power consumption:	21 000 W
Rated voltage:	230V
Rated frequency:	60 Hz
Rated fusing:	90 amp 3-pole
Conformity mark:	

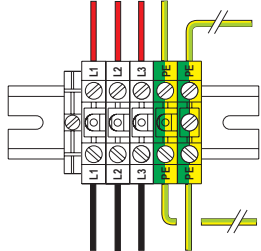
**Powerinput 3-pole
(max. 90 amp)
230V AC 60 Hz**





DANGER USA

HAZARDOUS VOLTAGE.
Contact will cause
electric shock!
Disconnect and lock out
power before servicing.

DANGER F

TENSION DANGEREUSE.
Tout contact entrainera une décharge
électrique !
Débrancher et sécuriser l'alimentation
électrique avant de procéder à l'entretien.

JK - 801047 "a" / 01.2004

04605 / 1



Bed tolerance in room

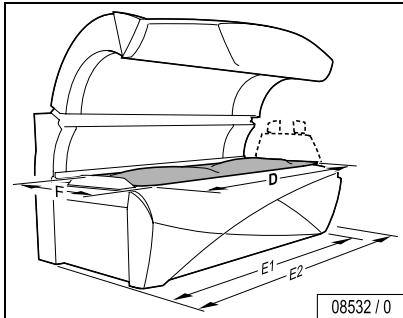
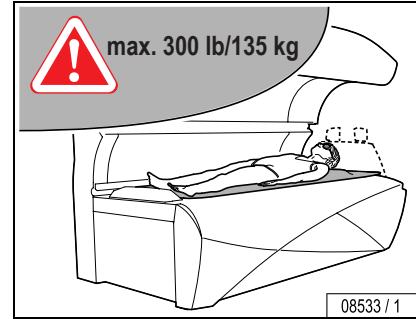
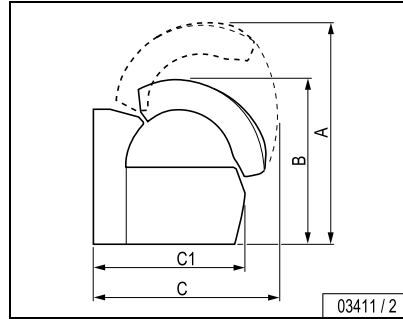
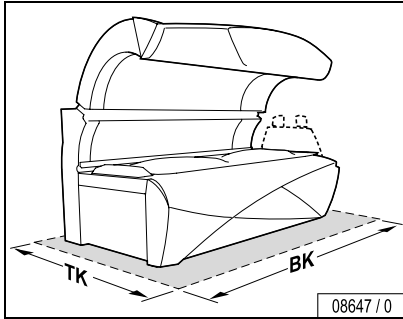

AFFINITY 950

A	=	73 1/4 in	1860 mm
B	=	53 9/16 in	1360 mm
C	=	62 in	1575 mm
C1	=	55 7/8 in	1420 mm
D	=	78 3/4 in	2000 mm
E1	=	89 in	2260 mm
E2	=	92 1/2 in	2350 mm
F	=	35 7/16 in	900 mm
BK	=	8 ft	2400 mm
TK	=	7 1/2 ft	2300 mm





Maximum room temperature / Humidity

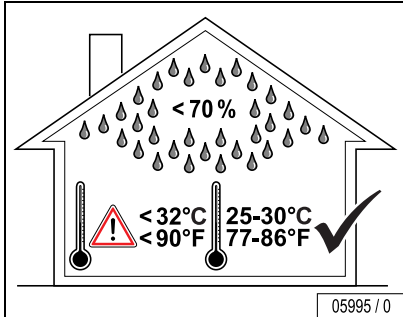

Acoustic level during tanning

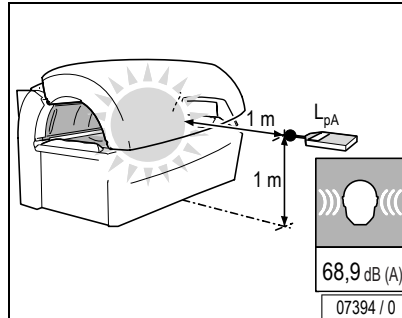
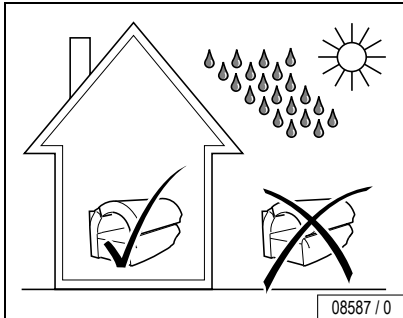
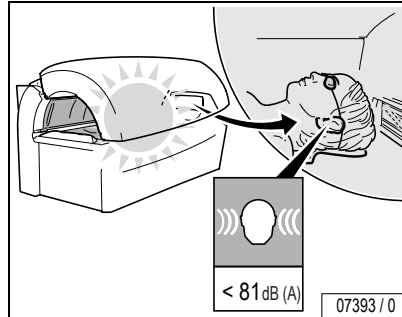



Maintenance instructions

Power Off device and secure against being switched on again



DANGER!

Extreme danger!

If work is to be performed on the devices, they must be powered off. That means that all live lines must be switched off. Switching off the device alone is insufficient, as certain points may remain energized. Therefore, switch off and lockout circuit breakers before performing any work.

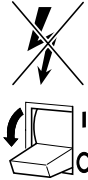

04049 / 0

- A strip of adhesive tape with the wording "DANGER do not switch ON!" may be applied over the actuation levers of circuit breakers which cannot be removed.

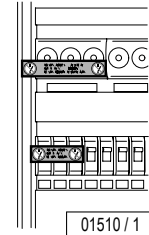

01510 / 1



DANGER!

Extreme danger!

Severe accidents can occur if the device is mistakenly switched on again. Immediately after powering off, secure all switches or fuses used for power against being switched on again.

A prohibition sign with the text: "Work in progress!"

- "Place:"
- "Sign may only be removed by:" must always be securely mounted immediately.



01511 / 1



DANGER!

Extreme danger!

Prohibition signs must not be hung on or touch live parts.



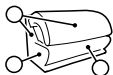

Deenergise de-
vice ...

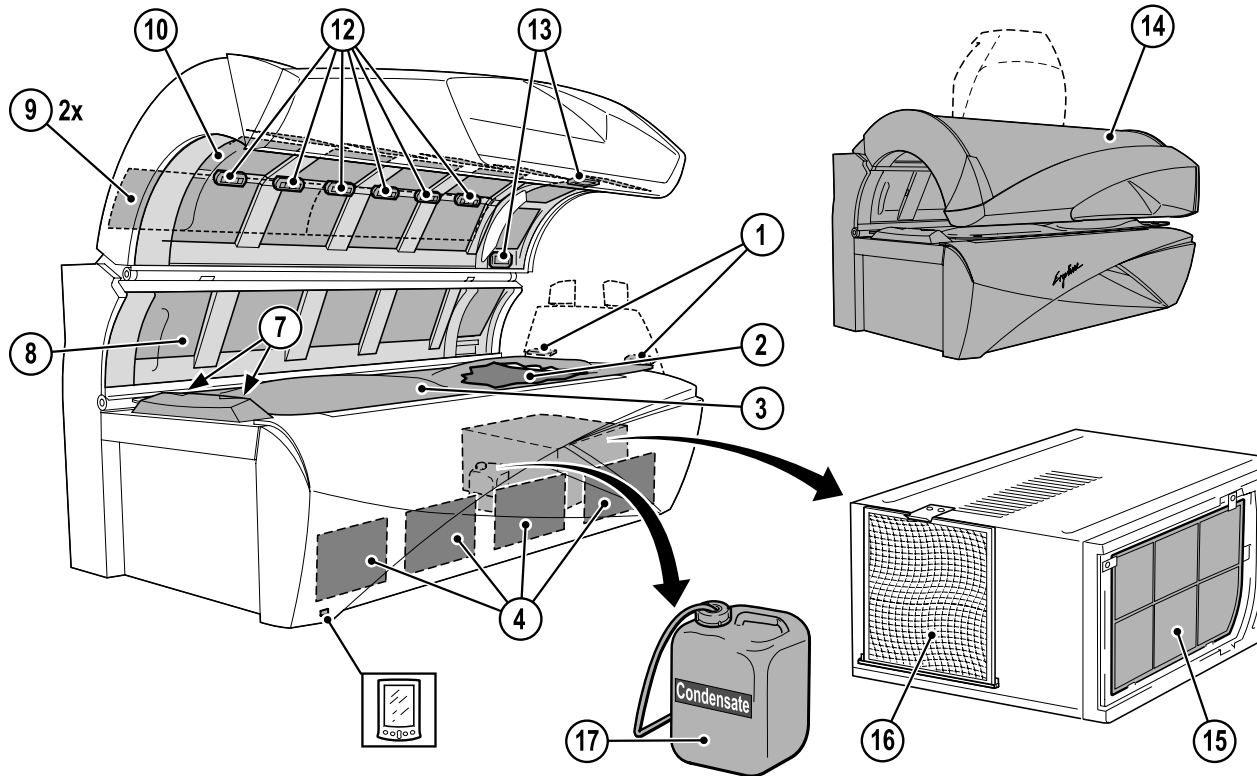

09915 / 0 ...



Scheduled cleaning

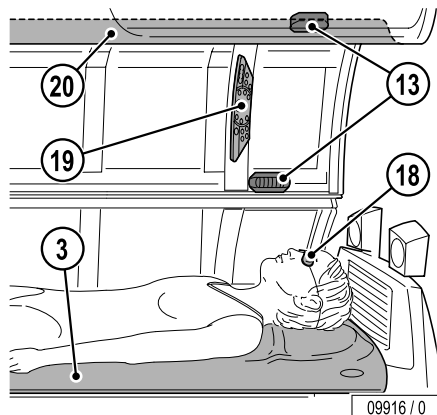

09916 / 0



Note:
Clean after every use.

③



18

⑬

Adjustable air nozzles

18

⑱



84592-..

18

⑲



18

⑳



18



Note:
Clean if necessary.

⑰



85

Deenergise de-
vice ...



WARNING – risk of eye irritation!

Protective goggles may only be cleaned with an approved disinfectant.

...







Scheduled cleaning – filters, filter mats

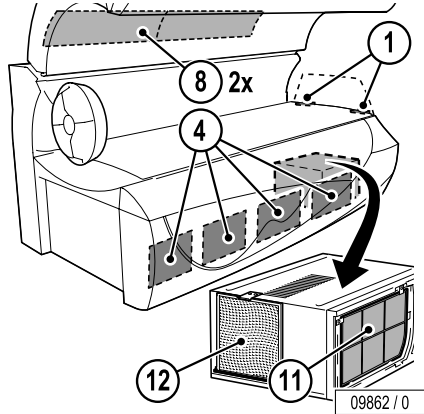

 /50 h



④	4 x		51937-..	80
⑧	2 x		800601-..	82
①	2 x	 1)	800278-..	83
⑪	1 x		51975-..	85
⑫	1 x		51937-..	85

1) = Shoulder tanner, optional

...









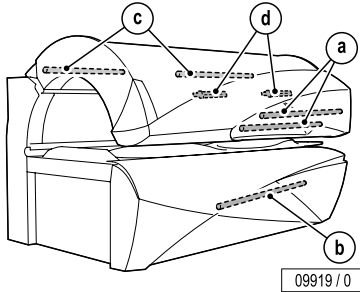











Scheduled replacement – accent lights



1,000 h



a)	2 x		blue	36 W	11 792-..	75
	or		white	36 W	1002113-..	
			yellow		1500706-..	
			pink		842758-..	
			red		1500713-..	
b)	1 x		blue	58 W	12063-..	77
	or		white	58 W	1002089-..	
			yellow		1500709-..	
			pink		1500712-..	
			red		1500717-..	
c)	2 x		blue	18 W	11 797-..	79
	or		white	18 W	1002513-..	
			yellow		1500708-..	
			pink		1500710-..	
			red		1500716-..	
d)	1 x		blue	30 W	11 377-..	73
a) b) d)	4 x		S10		10 047-..	73, 75, 77
c)	2 x		S2		10 013-..	79

...



Scheduled replacement – UV lamps and filter plates

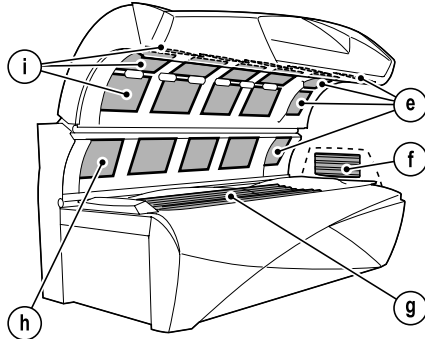

09921 / 0

500 h

e)	4 x		JK Ergoline 520 SE C	520 W	12645-..	66, 69
g)	19 x		VHP™ 12 Turbo Power Premium	160 W	12788-..	62
i)	12 x		JK Ergoline 520 SE C	520 W	12645-..	69
h)	4 x		JK Ergoline 520 SE C	520 W	12645-..	66
f)	7 x		VHP™ 25 ¹⁾	25 W	12562-..	64

1000 h

g)	19 x		S12		10002-..	62
f)	7 x		S10		10047-..	64

3000 h

e)	4 x		Ultra Performance 411		1001068-..	66, 69
g),h)	16 x		Ultra 611		1003259-..	66, 69



Note:

The UV high-pressure lamps used, Ergoline 520 SE C, can be operated with different wattages.



UV low-pressure lamps: Clean with plain water (damp cloth).



Filter panels: Clean with plain water (damp cloth).

...

1) = Shoulder tanner, optional



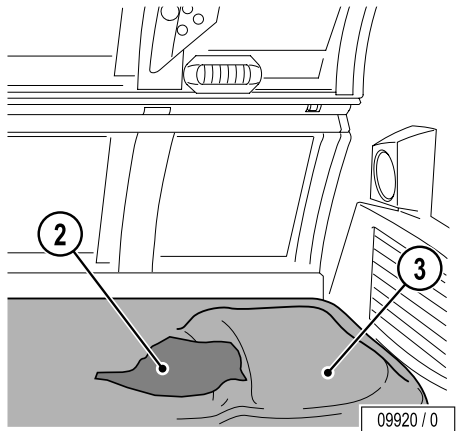

1500 h 

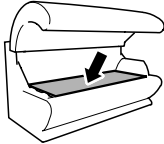

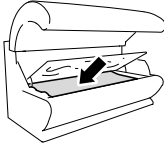
② 

③ 



1) = Shoulder tanner, optional

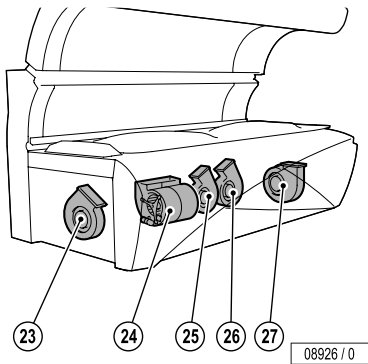

40 000 h



②③ 11713

②④ 12873

②⑤ 11713

②⑥ 11713

②⑦ 11713



Maintenance 



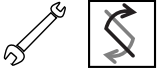

Relamping / maintenance instructions

It is imperative that you, the owner and/or operator, check all components for any signs of wear which may occur through normal use. Observe the cleaning and maintenance schedule specified in the maintenance table on Page 56 to 60.

Only replace UV low-pressure lamps with the original lamp type or with compatible lamps.

Only replace UV high-pressure lamps with the original lamp type or with compatible lamps.

Should you require any assistance or need additional information, please call Global Service USA at 800 445 0624, Monday through Friday 7:00 a.m. - 7:00 p.m. CT, Saturday 8:00 a.m. to 3:00 p.m.



CAUTION – Damage due to improper maintenance!

Improper maintenance can cause the device to be damaged or to become unusable.

- Always comply with the specified maintenance intervals.
- Follow the cleaning instructions.
- If the maintenance intervals for the UV lamps are exceeded or incompatible UV lamps are installed, the share of harmful UVB radiation may increase. Sunburn and other skin damage may result.



WARNING!

Danger: of burns from hot lamps and device parts!

If the tanning device was operated before being switched off and opened, lamps and housing parts may be hot.



- Before replacing lamps or other spare parts, wait until lamps and metal parts of the device have cooled down sufficiently.



Danger of pinching!

When opening and closing the tray, panels and covers, you can pinch your fingers.



Maintenance





Cleaning/replacing UV low-pressure lamps, sunbed base

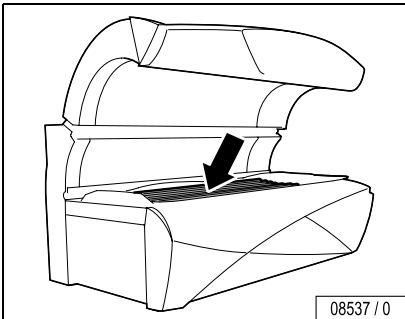
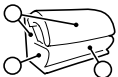

08537 / 0

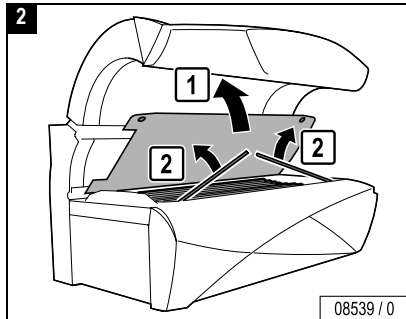

08539 / 0

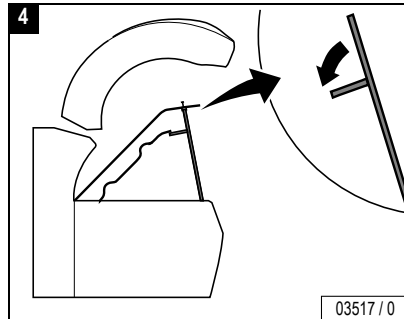

03517 / 0



Power Off!

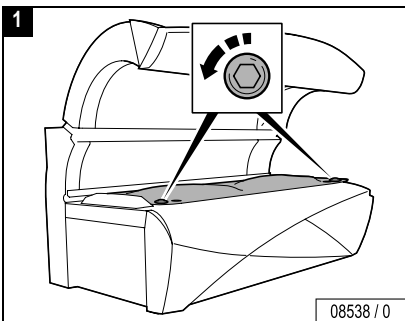

08538 / 0

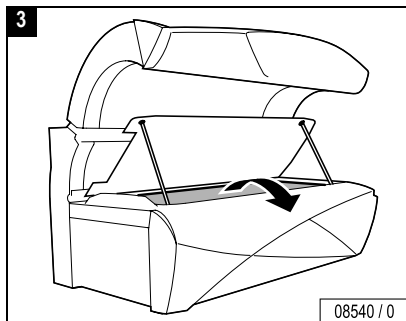

08540 / 0

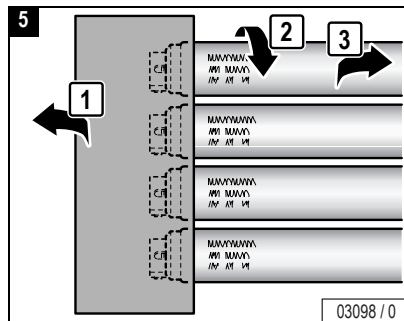

03098 / 0

...

Maintenance

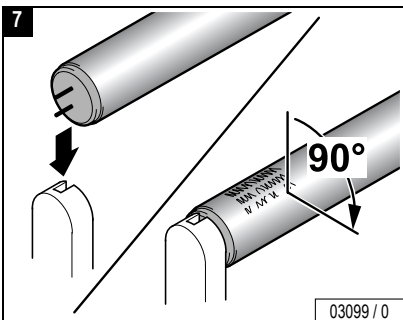
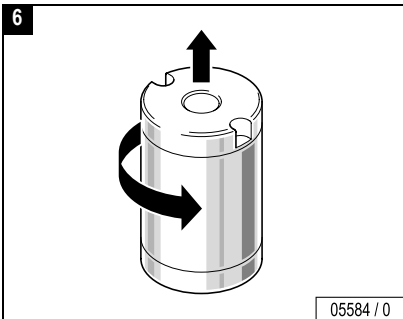

Close:

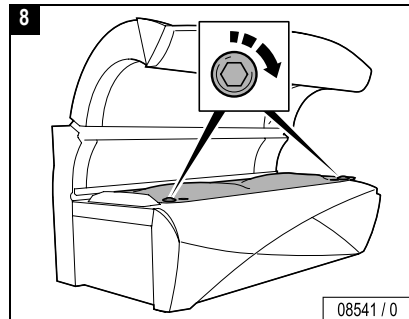

Maintenance





Cleaning/replacing UV low-pressure lamps in the optional shoulder tanner

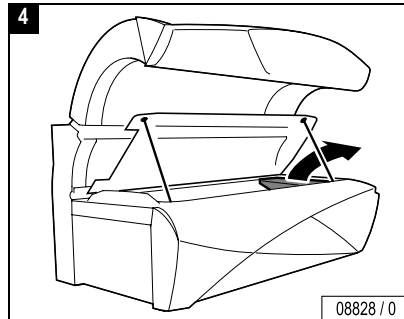
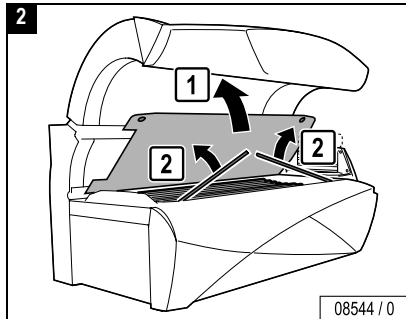
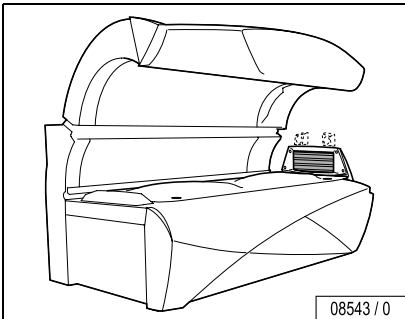
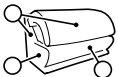

Maintenance



Power Off!

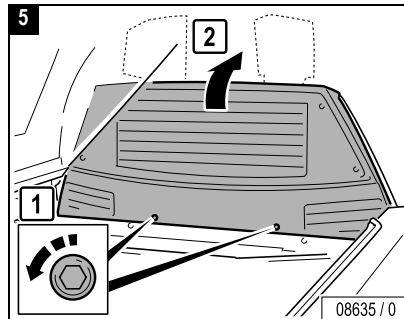
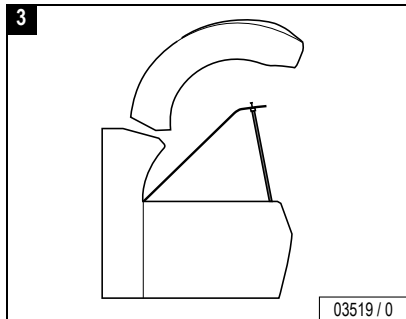
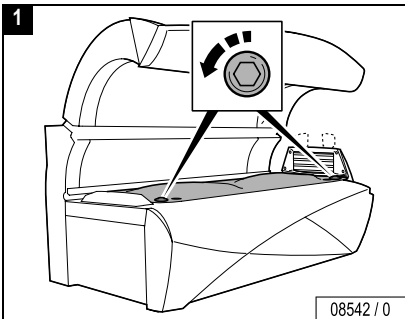

...

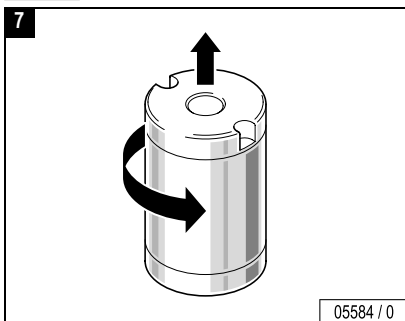
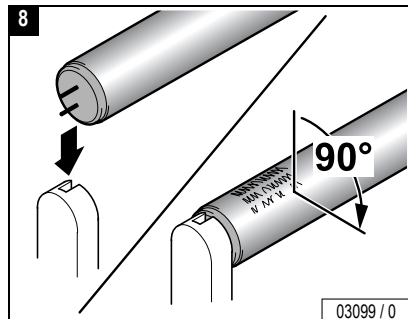
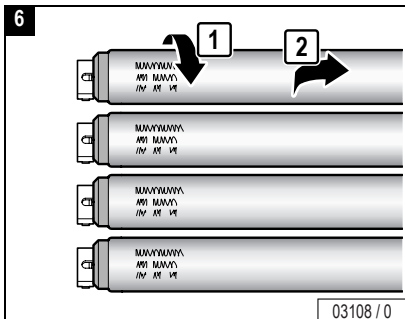

Close:

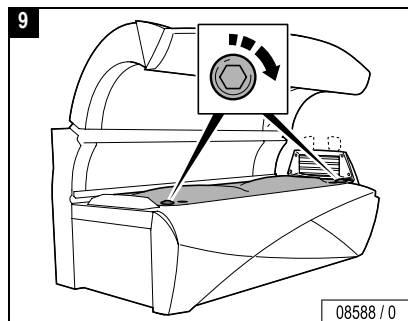



Cleaning/replacing UV high-pressure lamps, side section

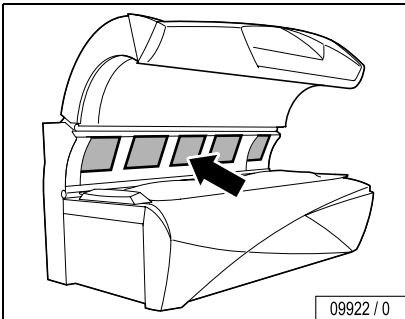
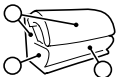

09922 / 0

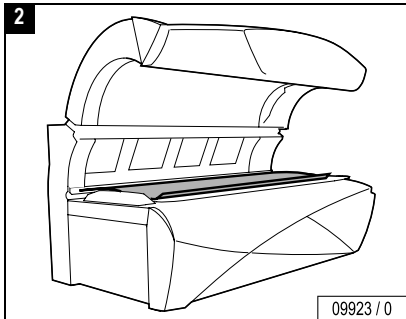

09923 / 0

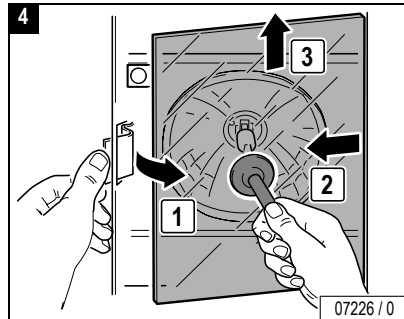

07226 / 0



Power Off!

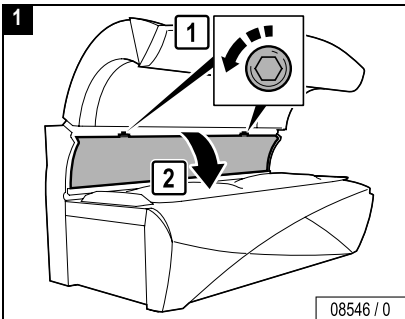

08546 / 0

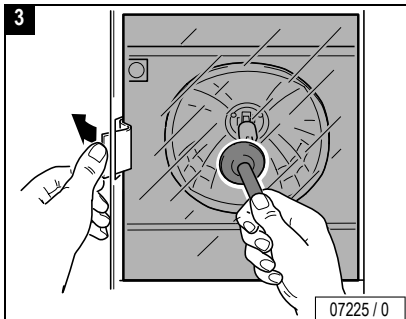

07225 / 0

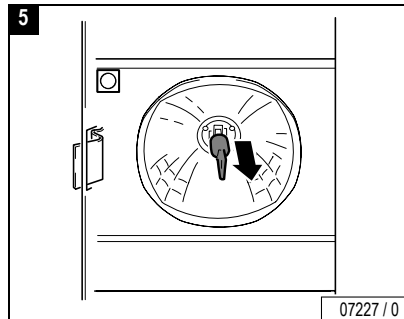

07227 / 0

...

Maintenance 

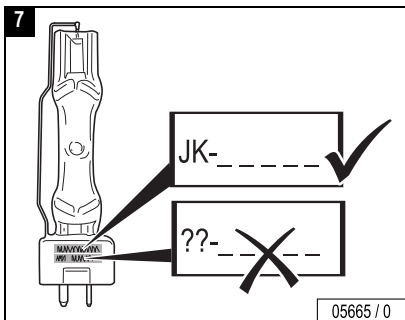
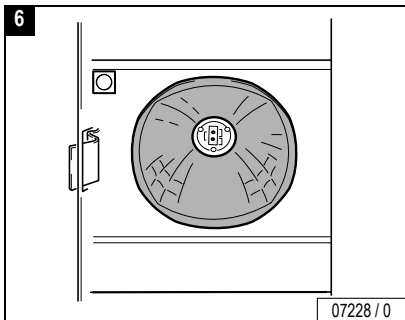

DANGER!

DANGER! Fire hazard!

High pressure lamps that have not been approved by Ergoline can explode. Hot lamp components can set other parts on fire. People can be killed or severely injured due to smoke and fume inhalation.

- Only fit high pressure lamps recommended by Ergoline.
- Clean the inside of the device regularly. Fluff is inflammable!

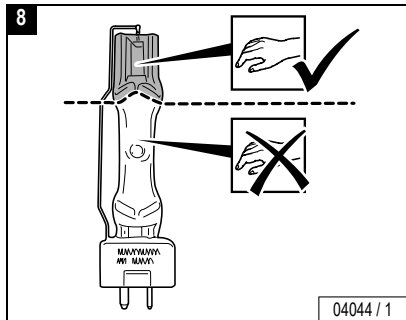

CAUTION!

Do not touch the glass bulbs of the UV high-pressure lamps with your bare fingers! Remove soiling thoroughly.

- Only touch new UV high-pressure lamp on the gripping surface – see Figures 8 and 9.

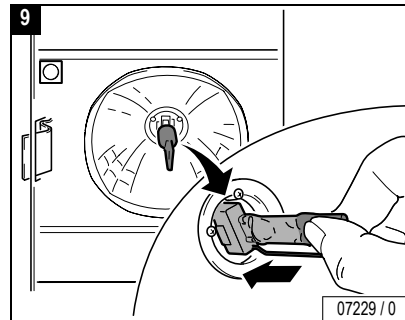



- Check safety switch.

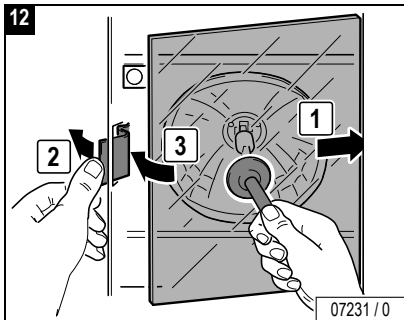
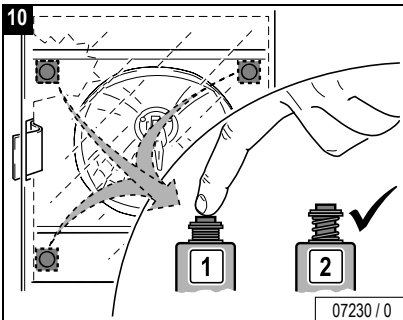

Close:

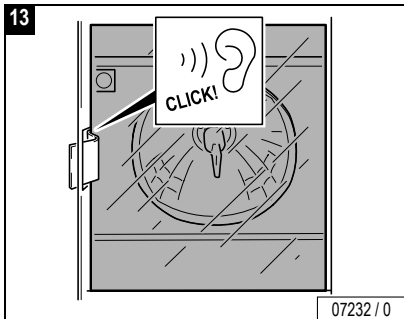
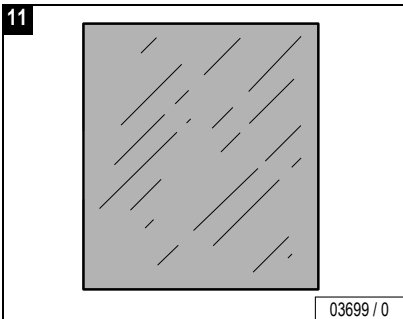
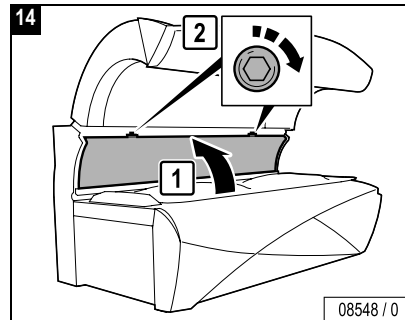

Maintenance



Cleaning/replacing UV high-pressure lamps, canopy

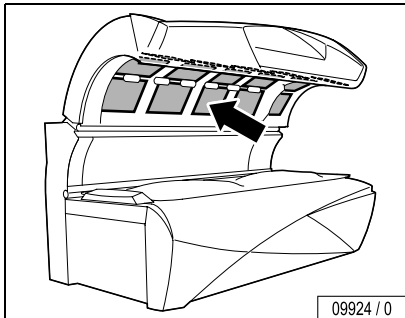
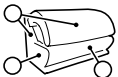

Danger of injury from the canopy panel!

WARNING!

The canopy panel is heavy and falls down by itself after unscrewing the 3 screws.

- Support canopy panel.
- Loosen screws in the specified order.



Caution!

Canopy panel may break if allowed to fall or if pressure is exerted on the reverse side of an open canopy. Such failure is not covered by manufacturer's warranty.



Power Off!

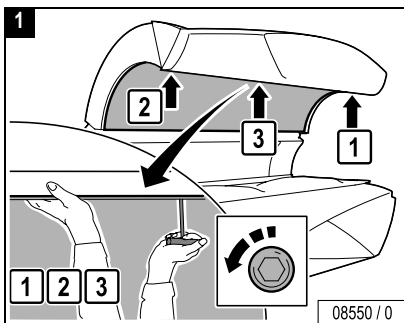

2

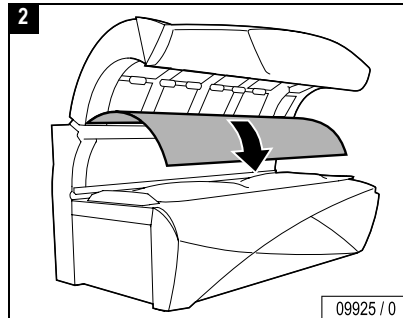

3

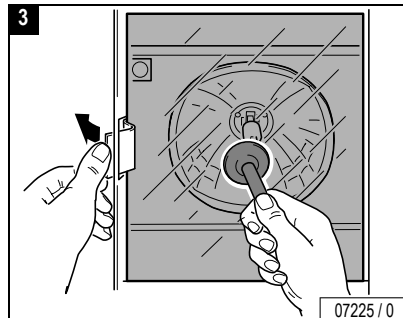

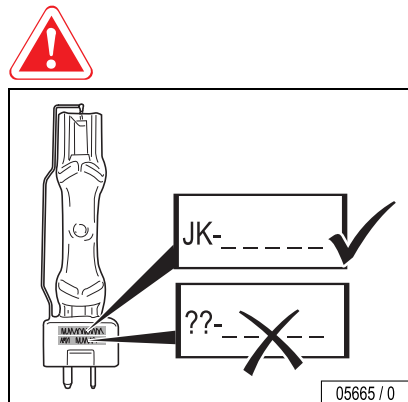
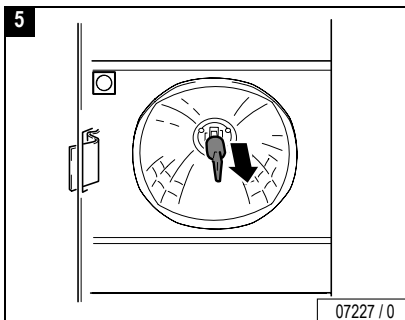
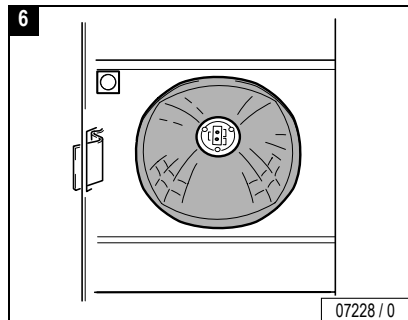
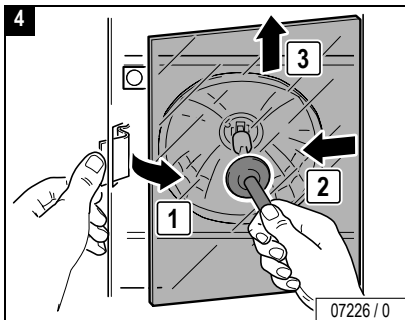

DANGER!

DANGER! Fire hazard!

High pressure lamps that have not been approved by Ergoline can explode. Hot lamp components can set other parts on fire. People can be killed or severely injured due to smoke and fume inhalation.

- Only fit high pressure lamps recommended by Ergoline.
- Clean the inside of the device regularly. Fluff is inflammable!

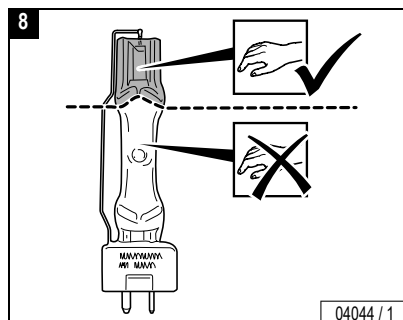

...



CAUTION!

Do not touch the glass bulbs of the UV high-pressure lamps with your bare fingers! Remove soiling thoroughly.

- Only touch new UV high-pressure lamp on the gripping surface – see Figures 8 and 9.

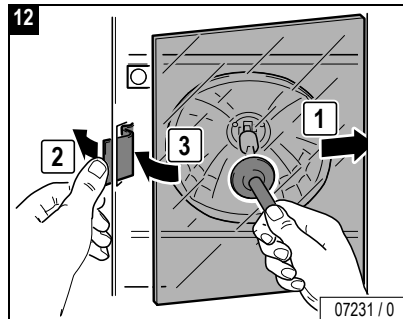
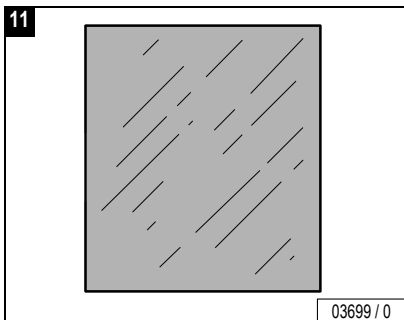
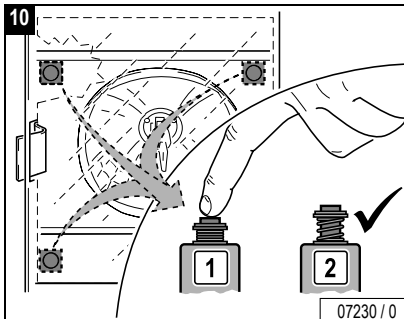
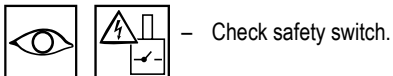
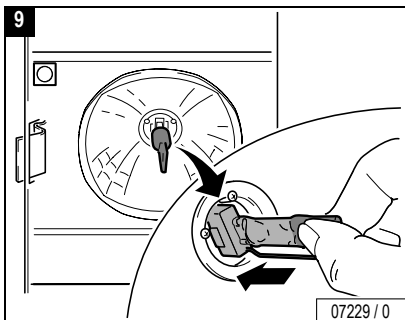

Maintenance

...

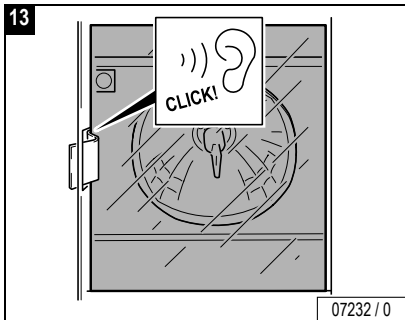

Close:

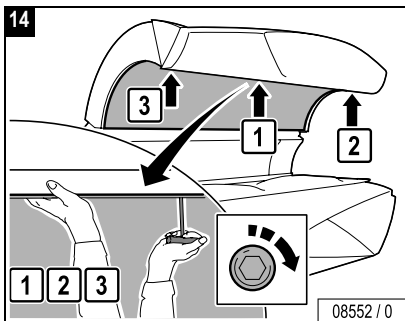



Cleaning/replacing interior lighting

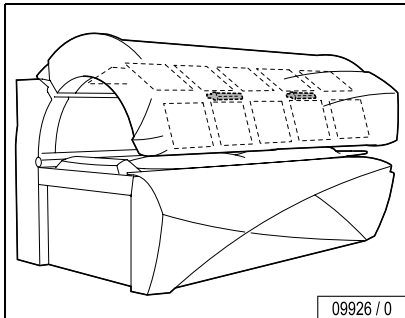
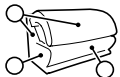

Danger of injury from the canopy panel!

WARNING!

The canopy panel is heavy and falls down by itself after unscrewing the 3 screws.

- Support canopy panel.
- Loosen screws in the specified order.



Caution!

Canopy panel may break if allowed to fall or if pressure is exerted on the reverse side of an open canopy. Such failure is not covered by manufacturer's warranty.



Power Off!

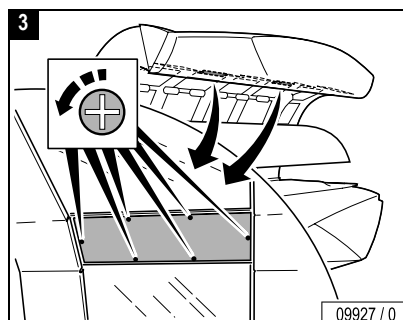
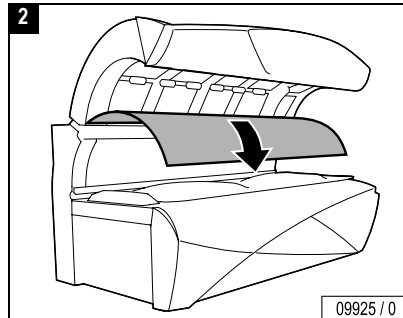
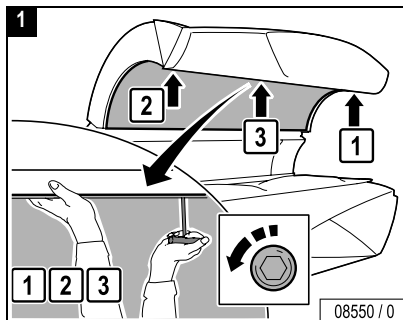

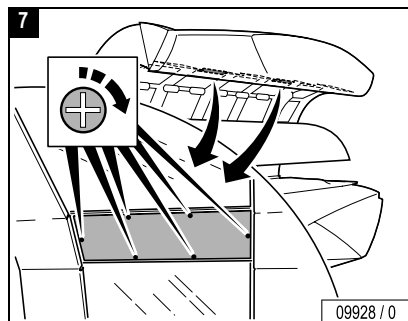
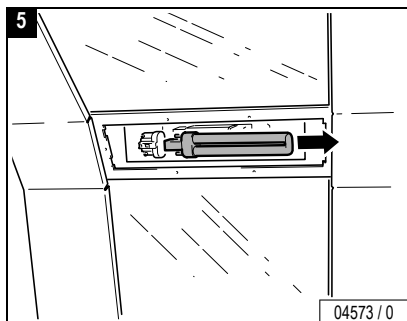
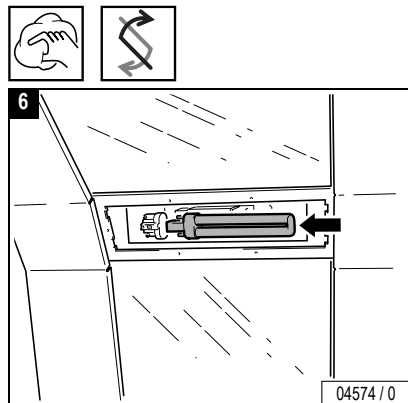
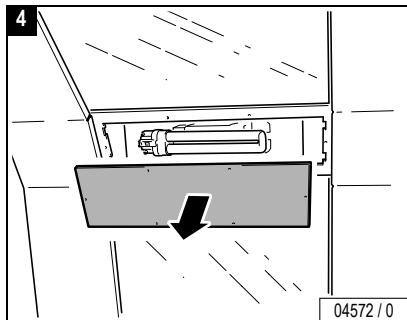

Close:

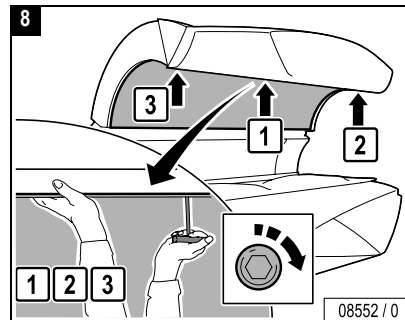



Cleaning/replacing accent light, canopy

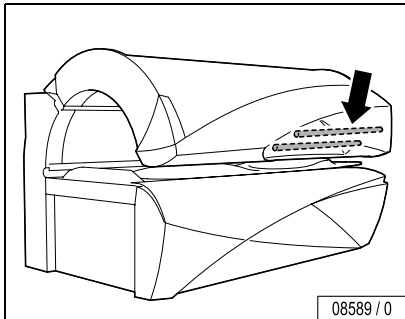
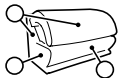

Caution!
Paint damage possible!
When screwing, maintain a separation from the bottom edge.



Power Off!

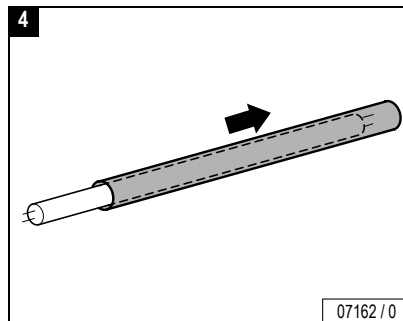
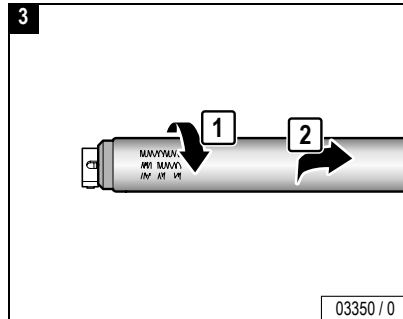
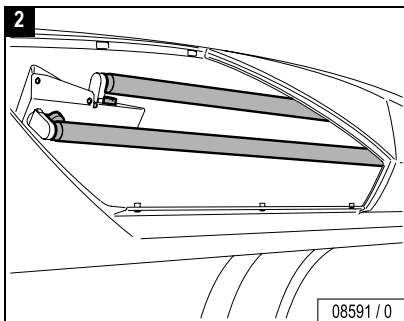
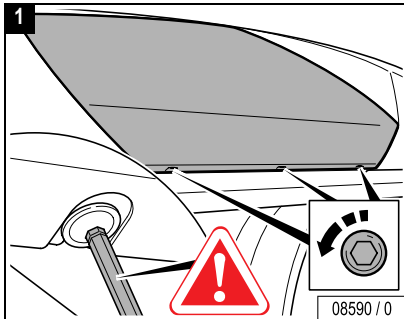

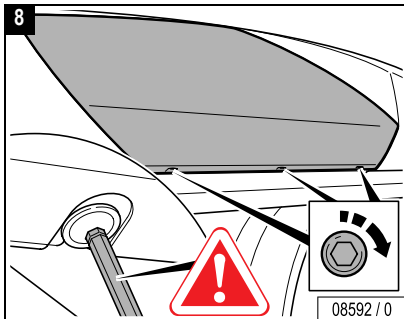
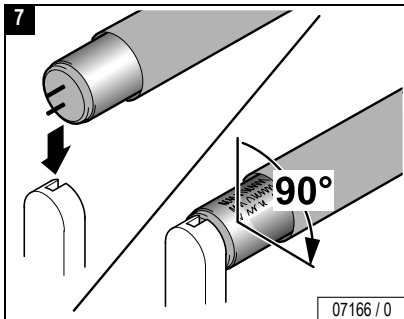
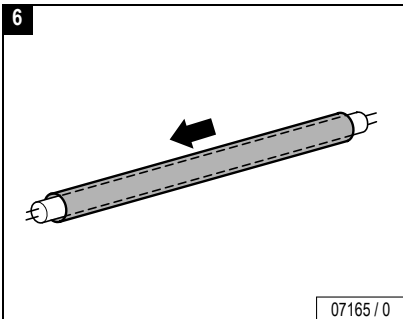
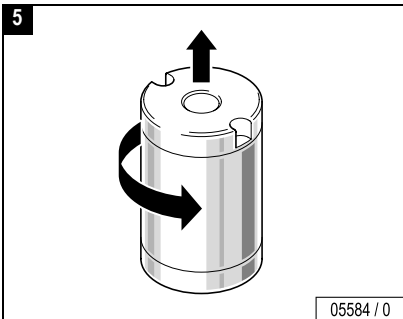

Maintenance 





Cleaning/replacing accent light, frontpanel

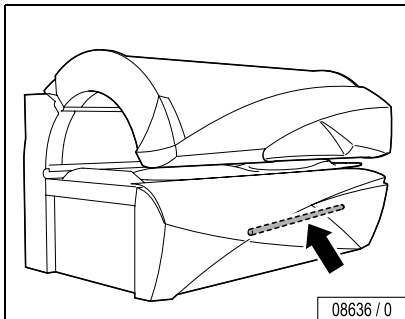
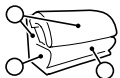

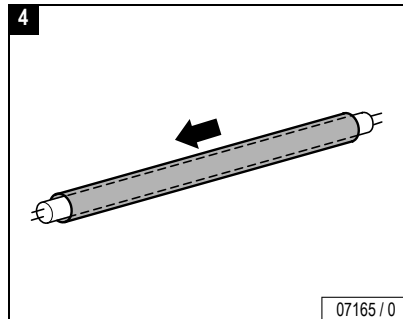
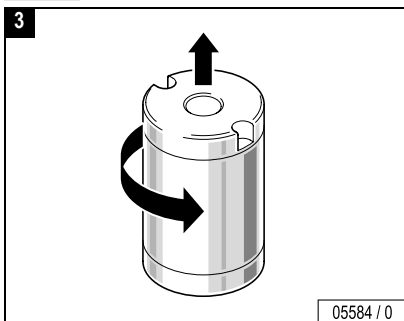
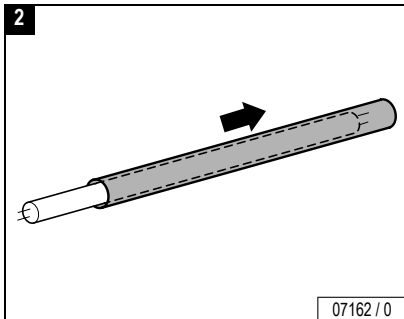
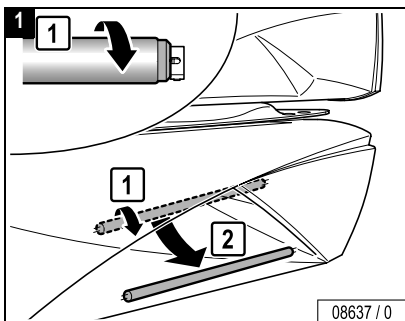

Power Off!

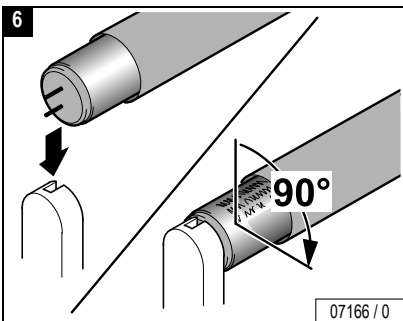
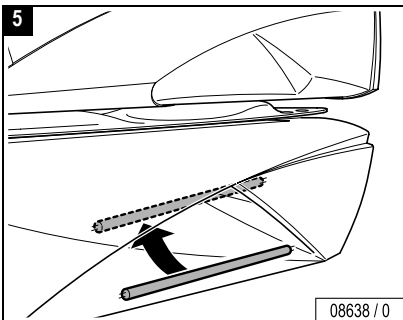

Maintenance

...



Maintenance 





Cleaning/replacing Ambient Light (optional)

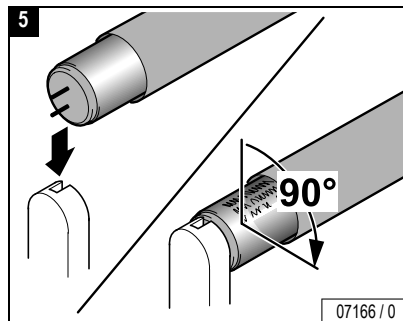
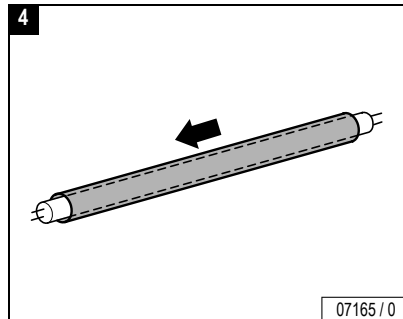
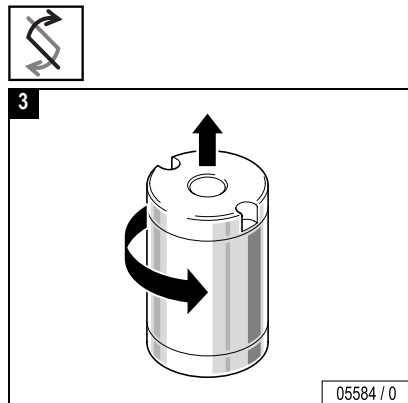
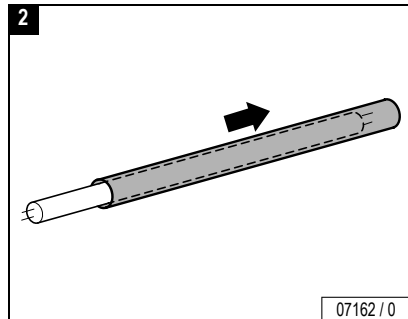
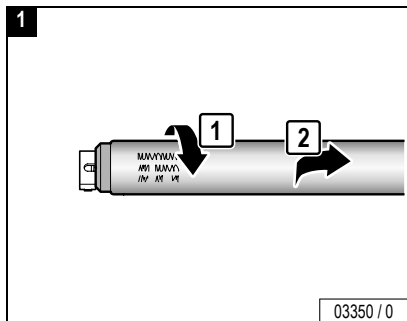
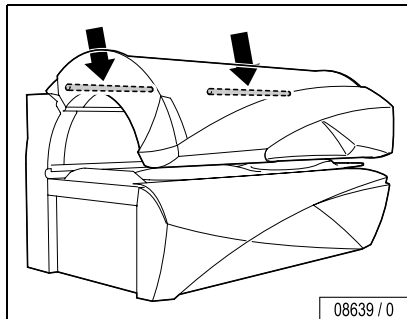



Cleaning filters, sunbed base

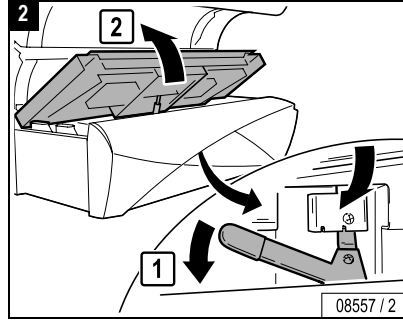
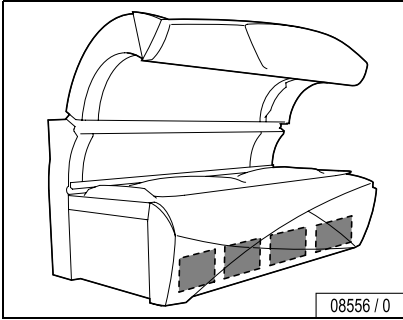
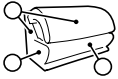

Hand-wipe lightly, dry or with water, or use a vacuum cleaner.

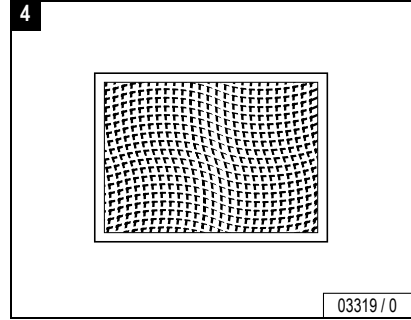

Power Off!

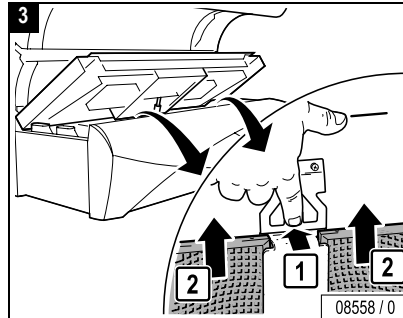
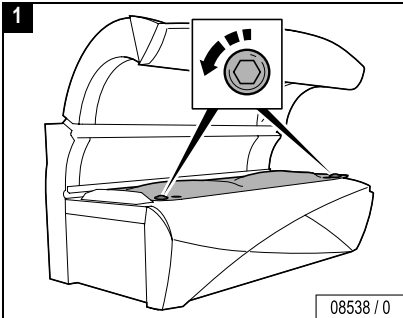

Attention! The system can be damaged by moisture!
When re-assembling, the cleaned filters must be dry.

...

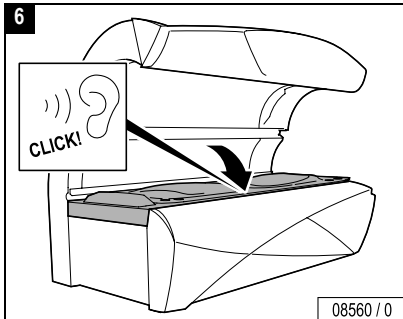
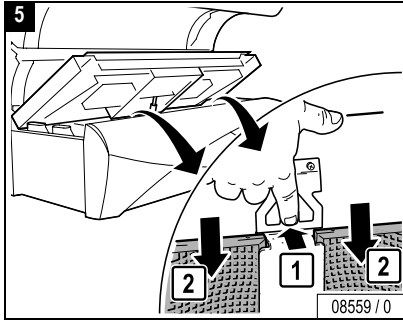

Close:

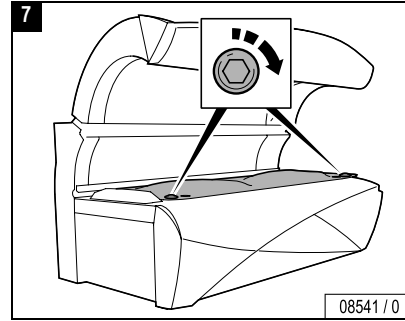

Maintenance





Cleaning/replacing filter mats, canopy

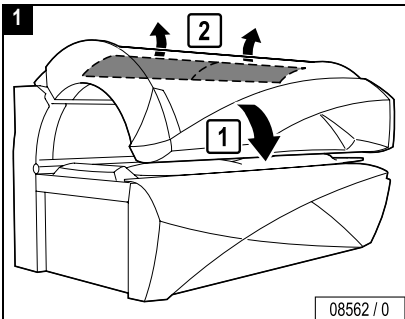
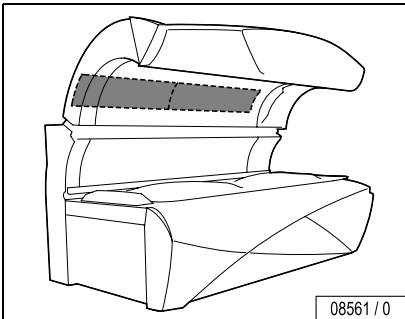
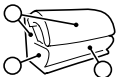

Rinse with water or replace.

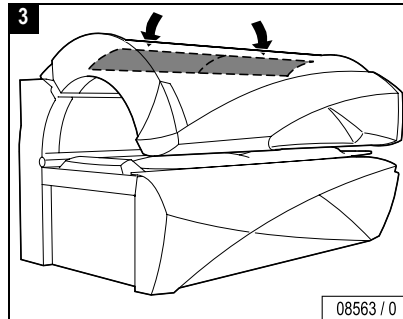
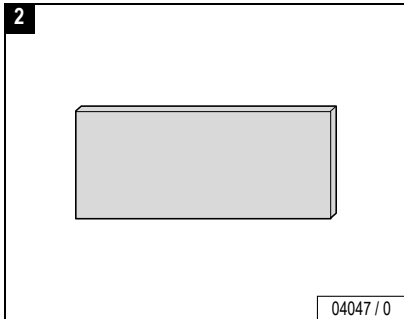

Attention! The system can be damaged by moisture!
When re-assembling, the cleaned filter mats must be dry.



Maintenance



Cleaning/replacing filter mats, shoulder tanner

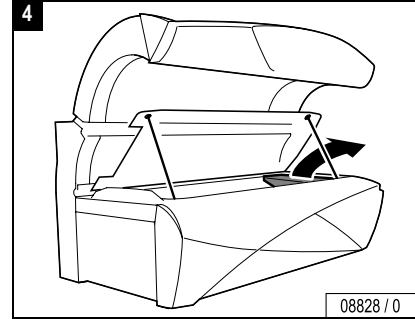
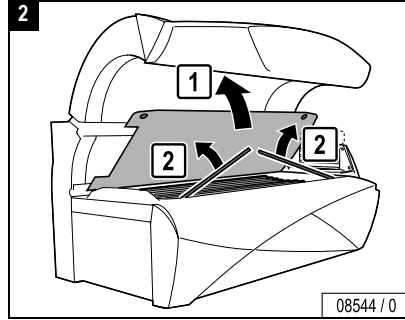
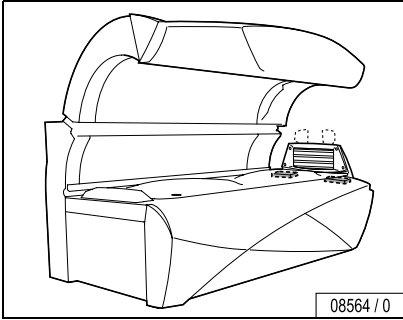
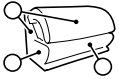

Power Off!

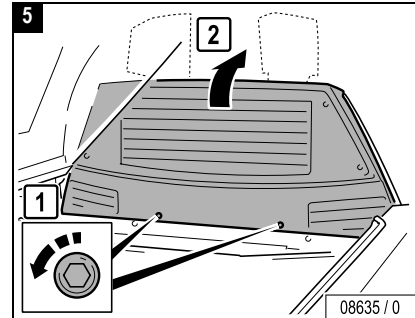
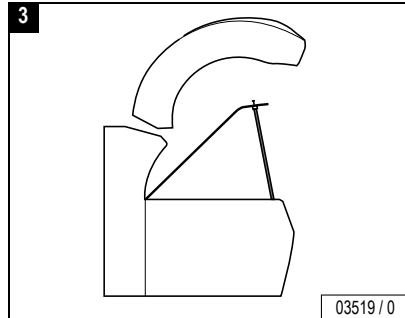
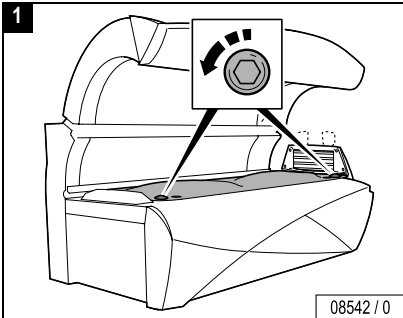

Maintenance

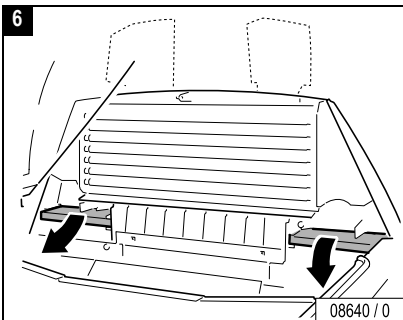

Rinse with water or replace.

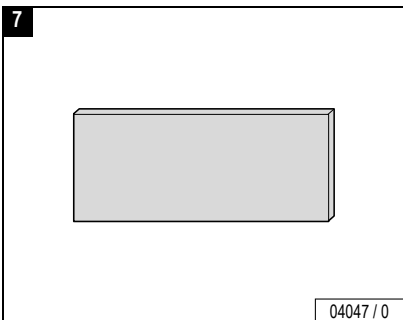

Attention! The system can be damaged by moisture!

When re-assembling, the cleaned filters and filter mats must be dry.

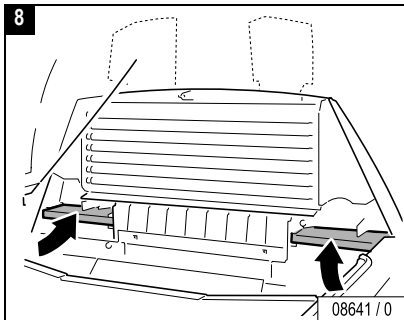

Close:

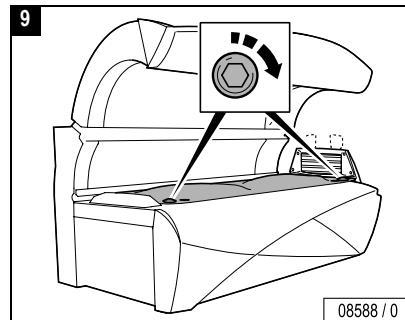



AFFINITY 600/800

Air condition/Tempronic: Cleaning/replacing the filter mat, cleaning the cooling fins

 **Regelmäßige Sichtprüfung!**
Regular visual check!
Contrôle visuel régulier!

Gefahr von Geräteschäden!
Risk of damage to equipment!
Risque de détérioration de l'appareil!

Filtermatten reinigen!
Renew filter mats!
Nettoyer les mats filtrants!

Kühlrippen reinigen!
Clean cooling fins!
Nettoyer les barres de refroidissement!

Kondensatbehälter entleeren!
Empty condensation container!
Vidanger le réservoir à condensation!

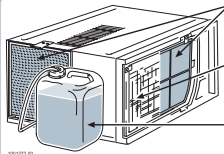

161073-00

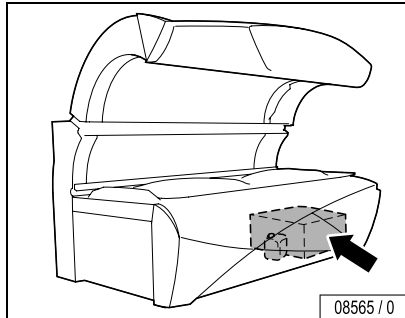
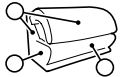

Power Off!

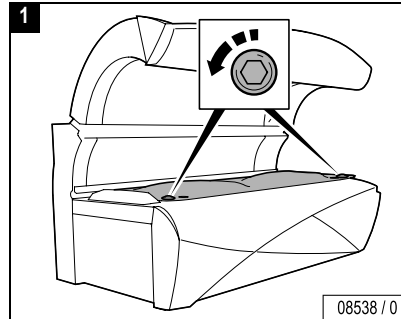

Attention! Risk of damage to the system!

Check the filter mat and the cooling fins on the air conditioner regularly and clean as necessary.

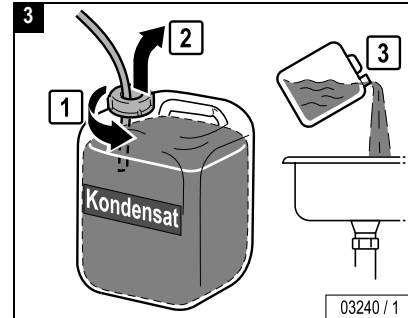
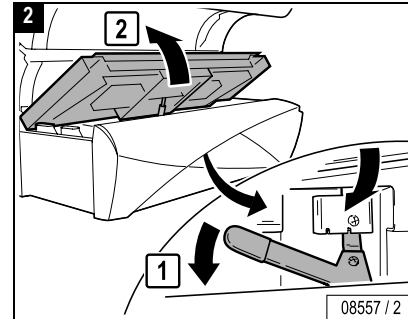

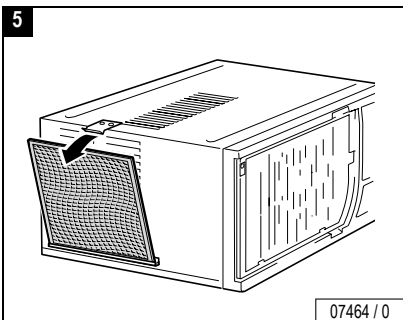
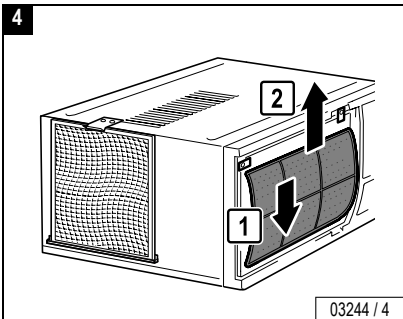

Clean carefully (vacuum or wash) or replace.

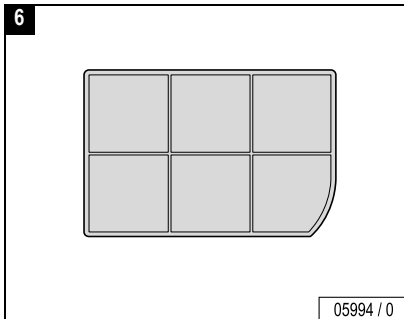

Hand-wipe lightly, dry or with water, or use a vacuum cleaner.

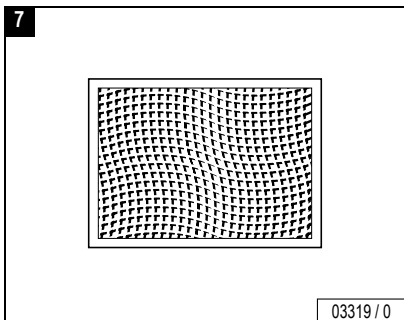

Clean carefully.

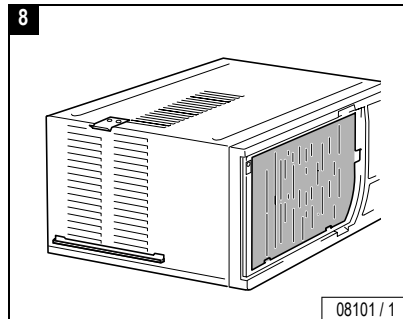

Attention! The system can be damaged by moisture!
When re-assembling, the cleaned filters and filter mats must be dry.

...

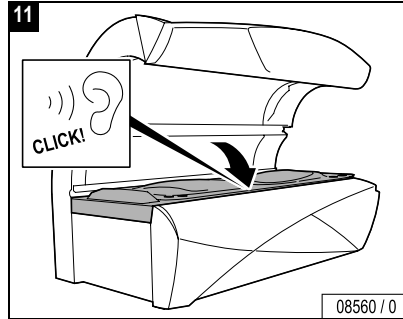
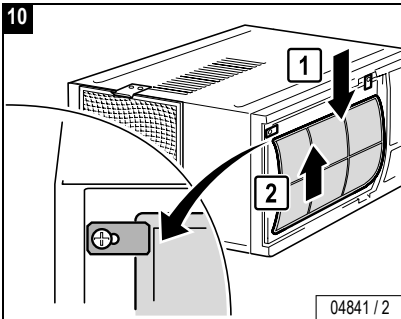
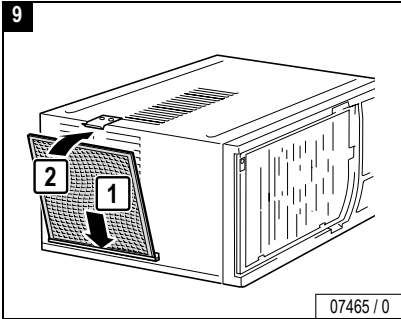

Close:

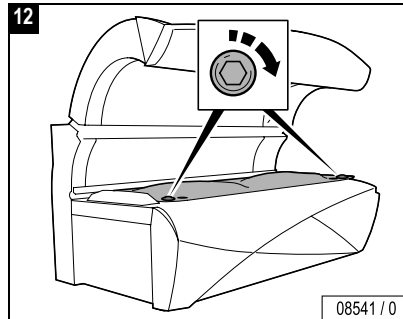

Maintenance





Changing presets with the control panel

The setting mode enables you to call up operating states and make alterations to current settings.

Changing to Presetting mode

- Press the buttons and simultaneously for at least five seconds outside a tanning process.

appears in the display.

- Enter the code (see Page 89).
- Press the START/STOP button four times when you run the Presetting mode for the first time.

briefly appears in the display, then (Function 1) and the presetting value are displayed alternately (see column "On delivery").

- By pressing the button you scroll up to the next function (from -01- to -19-).
- By pressing the button you scroll down to the next function (from -19- to -01-).

Changing presets

Increase the preset value:

- Press and hold the START/STOP button while simultaneously pressing the button.

Decrease the preset value:

- Press and hold the START/STOP button while simultaneously pressing the button.

Reset to the last value set:

- Press the START/STOP button.

Reset to the delivered state:

- See function .







Note:

The sunbed will automatically return to 'idle' mode 30 seconds after the last button was pressed.

The presets are listed beginning on Page 91.



Defining a code

- Select Function .
- Press the START/STOP button for 3 seconds until  appears.
- Press the desired buttons consecutively:
- Press the buttons in the same sequence when  appears again.
-  appears in the display. The set code has been saved.
- Please note the code for Customer Service.

If you know the old code, you can define a new code at any time. We recommend that you already set a new access code during the initial start-up.





Changing presets with a hand-held unit

Some data can also be displayed and changed with a commercially available hand-held unit (e.g. from Palm). For this purpose you require special software (available in German and English). Please call 1-866-243-9861 for more details.



Caution!

The code for access via the infrared interface is preset in the software of the hand-held unit, and can therefore be used with any unit. Anyone, who downloads the software from the Internet can access the unit data with a hand-held unit. Please note that Customer Service changes the preset access code during initial start-up – see software operating manual. Please note the new code for future use!

This code is independent of the access code for the presets via the control panel.



Note:





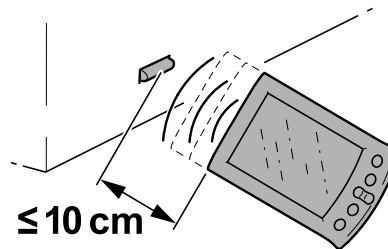

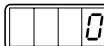

Please read the operating manual for the Ergoline software for instructions on how to display or change data with a hand-held unit.

Information on operating the hand-held unit is contained in the manufacturer's documentation.

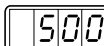

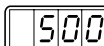
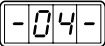
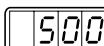
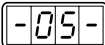
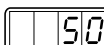
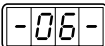
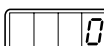
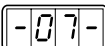
IR Function

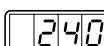
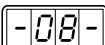
04002 / 1

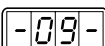
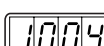
No.	Description	on delivery
	Total number of operating hours	
	Remaining operating time of UV low-pressure lamps (hours)	
	Remaining operating time of UV high-pressure lamps (hours)	
	Remaining operating time of shoulder tanner lamps (hours)	
	Remaining operating time of filter mats (hours)	
	Air conditioning operating hours	
	Decorative lighting operating hours (minutes) When the maximum value is exceeded: Display  = continuous operation	
	Fan run-on time (minutes)	
	To set the time	





No.	Description	on delivery
	To reset the device to ex-works setting (all functions)	
	To set the access authorisation code to enter setting mode (see page 89)	
	Adjust volume for voice output (Voice Guide)	
	Adjust volume for music output (Sound System)	
	Ambient temperature setpoint value (°C)	
	Recycle air during fan run-on time (+ = on / - = OFF)	
	Lower temperature limit of air conditioner	



Troubleshooting

In the case of a fault, a fault code appears on the display to simplify localizing of the fault cause:

- If a fault occurs, the fault code flashes in the display.
- If several faults occur, the fault messages are displayed alternately.
- The fault remedy is acknowledged by pressing the  button.

If the fault cannot be eliminated, inform Customer Service:



Global Service USA

A Div of JK Products & Services, Inc.
#1 Walter Kratz Drive
Jonesboro, AR 72401

☎ 800-445-0624

☎ 870-935-9046

e-mail: support@jkamerica.com

<http://support.jkamerica.com>







Error	Meaning	Correction
	Fault in temperature sensor for UV low-pressure lamps	
	Temperature sensor for room	
	Panel switch for shoulder tanner	
	Air-vane switch does not switch on with fan running	
	Air-vane switch does not switch off 1 minute after fan switches off	
	Fault in front face tanner	
	Fault in center face tanner	
	Fault in rear face tanner	
	Fault in face tanner side section	
	Panel safety switch on decorative panel on canopy	

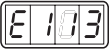

Error	Meaning	Correction
	Emergency switch-off time exceeded	
	I ² C bus fault	
	Switching error in series circuit of safety switch	
	Auxiliary controller	
	Heating controller	
	Face tanner controller	
	Speed control 1	
	Speed control 2	
	Audio amplifier	
	Channel selection	

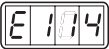

Error	Meaning	Correction
	Real-time clock	
	Parameter memory	
	Incorrect equipment of controller	

Index

A

Accent lights
 Cleaning/replacing 77
 Maintenance schedule 57
 Accessories 17, 26
 Acrylic glass, cleaning 20
 Air condition
 Filter mat 85
 Air condition, switching off 35
 Allergies 22
 Ambient lights, cleaning/replacing 79

B

Body tanners, regulating 33
 Body ventilator, speed 38

C

Cabin lighting, cleaning/replacing 79
 Care 19
 Changing presets 88
 Cleaning 20
 Cleaning schedule 55
 Cleaning/replacing accent light, frontpanel. 75
 Code, defining, presets 88
 Conformity mark 50

Contact lenses 22
 Cooling fins, air condition 85

D

Description of tanning device 24, 25
 Disinfection 20
 Disposal of lamps 21

E

Ending tanning session 28
 Environmental protection 21
 Equipment 17
 Error codes 93

F

Facial tanners, regulating 30
 Fault codes 93
 Filter mat, air condition 85
 Filter mats
 Canopy 82
 Shoulder tanner 83
 Filter panels, maintenance schedule 58
 Filters, sunbed base 80
 Frequency 50
 Fusing 50

G

Glasses 22
 Global Service USA, address 3
 Guidelines 17

H

Hand-held unit, changing presets 90
 Head nozzles, speed 40

I

Intended use 10
 Interior lighting 73
 Interrupting tanning session 28

L

Lamps, disposal 21

M

Maintenance
 Maintenance and care 19
 Maintenance schedule 56, 59
 Overview AFFINITY 500 54
 Overview AFFINITY 800 56, 59
 Safety information 61
 Make-up 22
 Medication 22

Index

Music channel.....	46	Skin sensitivity.....	22
O		Skin types.....	4
Operator commitments	10	Spare parts.....	19
Overview, operating elements	24, 25	Starters, maintenance schedule.....	58
P		Starting tanning.....	27
Packaging.....	21	Sunbed, how to use it.....	27
Plastic surfaces.....	20	Surround cooling, adjust speed.....	38, 40
Power consumption	50	T	
Power, switching off.....	53	Tanning.....	27
Preparation time	27	Tanning instructions.....	22
Presettings.....	88	Technical data.....	50
Changing with a hand-held unit	90	Timer.....	27
Changing with the control panel.....	88	Troubleshooting	93
Proper use	10	U	
Protective goggles	22, 27	Using the sunbed	27
R		UV high-pressure lamps	
Relamping.....	61	Canopy.....	69
Running time of accent lighting.....	29	Side section.....	66
S		UV lamps, maintenance schedule.....	58
Safety information, maintenance	61	UV low-pressure lamps	
Scheduled cleaning	55	Sunbed base	62
Scheduled maintenance	56, 59	UV low-pressure lamps, shoulder tanner ...	64
Settings during start-up.....	28	V	
Showering.....	22	Voltage.....	50
		Volume.....	48

JK-Products, Inc. – Limited Warranty

JK-Products, Inc. warrants its products to be free from defects in materials and workmanship under intended normal use as described in the unit's Operation and Instruction Manual, for a period of three (3) years from date of sale.

This Limited Warranty applies only to the original purchaser of the equipment through JK-Products, Inc. or its authorized dealer or distributor, and is not transferable.

Global Service USA obligations under this warranty are limited to repair or replacement of any defective part without charge for that part to the original purchaser, with the following exceptions:

- A Fluorescent lamps are warranted against defects for a period of thirty (30) days from date of sale.
- B Only parts obtained through JK-Products, Inc., its authorized dealers or distributors may be used. Transportation costs for parts shipped to the consumer and the return of defective parts to Global Service USA are not included.
- C Labor will be furnished without charge for ninety (90) days from date of purchase only. All labor and related charges must be authorized by Global Service USA prior to start of repairs, and must coincide with Global Service USA established rates and time allotment policy.
- D Acrylic: Refer to Manufacturer's Acrylic Warranty Policy.

It is imperative that the original customer completes and returns the enclosed warranty card within 10 days after purchase to insure valid registration and coverage for potential claims.

If the warranty card is not registered, proof of purchase from JK-Products, Inc. or its authorized dealer or distributor will be required prior to any consideration on warranty claims. This could result in service delays.

This warranty is extended to the individual or legal entity, whose name appears on the warranty registration card filed with Global Service USA, or whose name appears on the original sale document and may not be transferred to any other individual or legal entity.

This warranty does not apply to any failure of the product, or any parts of the product due to alterations, modifications, misuse, abuse, accident, improper maintenance, improper installation, acts of God or if the serial number on the product has been removed, altered or defaced. Adequate packaging must be used for returned goods to prevent freight damage.

There are no warranties which extend beyond the description on the face hereof. There is no express or implied warranty of fitness of merchantability.

The remedies provided in this limited warranty are the exclusive remedies provided to the purchaser by Global Service USA and are provided in substitution of all other remedies. Consequential and incidental damages are excluded.

No person, firm or corporation is authorized to obligate JK-Products, Inc. for any liability in connection with the sale or use of these goods.

Warranty

Limited Acrylic Warranty

JK Products, Inc. warrants its acrylic sheets to be free from defects in material and workmanship, under intended normal use, for a period of one (1) year from date of sale of the tanning bed. Due to the tanning lotions, cosmetics, disinfectant and improper cleaners used on tanning surfaces that cannot be controlled by JK Products, Inc., after the first thirty (30) days of warranty period acrylic will be subject to a prorated cost to the consumer.

JK Products, Inc. obligations do not include transportation charges on replacement acrylic.

JK Products, Inc. assumes no liability for the cost of removing defective sheets or installing replacement sheets, nor for damage to persons or property.

To make a claim, contact an authorized dealer or distributor of JK-Products, Inc. or Global Service USA with the model number, the serial number, and the date of purchase of the bed in which the acrylic will be used.

There are no warranties which extend beyond the description on the face hereof. There is no express or implied warranty of fitness or merchantability.

The remedies provided in this limited warranty are the exclusive remedies provided to the purchaser by Global Service USA and are provided in substitution of all other remedies. Consequential and incidental damages are excluded.

Global Service USA

A Div of JK Products & Services, Inc.
#1 Walter Kratz Drive
Jonesboro, AR 72401

☎ 800-445-0624

☎ 870-935-9046

e-mail: support@jkamerica.com

<http://support.jkamerica.com>

Warranty

Warranty Claims

Policy & Procedures

1. When to file a Warranty Claim:

In the event that your tanning system is not functioning properly under intended normal use as described in the unit's Operation An Instruction Manual, you may then have established cause to file a Warranty Claim.

**NOTE:**

Both the tanning system and legal registered owner must meet the criteria established under JK Products, Inc. Limited Warranty as described in this manual before any Warranty Claim will be considered.

2. Where to call to place a Warranty Claim:

JK-Products, Inc. is supported nationwide by an extensive dealer/distributor network through whom the majority of our units are sold. These dealers/distributors are required by contract to stock sufficient parts to meet the various warranty and nonwarranty needs of their customers.

Therefore, in order for you to properly file a Warranty Claim, you must locate the name and phone number of the dealer/distributor through whom you purchased your unit. Normally this information can be easily located either on your paid invoice or other proof of purchase documentation that you received when taking delivery of the unit.

Next, notify the dealer/distributor of the serial number, model number and date unit was purchased. This will initiate the Warranty Claim process.

Upon determination of the problem, your dealer/distributor can then supply you with the part(s) and proper instructions to return your unit to working order.

Each dealer/distributor has their own internal procedure for handling Warranty Claims and credits.

**NOTE:**

JK-Products, Inc., the manufacturer, does not involve itself in the direct handling of a Warranty Claim except where mitigating circumstances apply and where required by law.

**NOTE:**

If part returned to Global Service USA proves to be operational and not defective, or if product code numbers on part do not correspond with individual unit date on file with Global Service USA, then a 30% restocking fee will be charged in addition to the retail purchase price of part.

Acknowledgment of the Agreement is not required for acceptance of the foregoing stipulations.

Labor Warranty Claim/Credit Procedures

Global Service USA furnishes labor without charge for a period of 90 days from date of purchase. All labor and related charges must be authorized by Global Service USA prior to start or repairs, and must coincide with Global Service USA established rates and time allotment policy.

Please contact our Service Department for authorization and billing procedures.

Warranty

Limited Lifetime Warranty

Global Service USA warrants specific individual components of the tanning system against defects in materials and workmanship for the life of the product. Coverage is limited to units purchased after November 1, 1994.

This warranty is restricted by the following components only:

- Steel Back Panels
- Structural Steel Frame Components
- Exterior Steel Body.



NOTE:

Components are warranted on an individual basis and not as they may effect the complete product.

Warranty coverage does not include cosmetic abnormalities such as scratches, nicks, dents, rust, oxidation of paint or other cosmetic changes that do not interfere with the designed function of the unit.

This warranty does not include failure of the product due to alteration, modifications, misuse, abuse, improper maintenance, improper installation or repair.

This warranty is not transferable and is only applicable to the original purchaser named on a completed and registered warranty record at JK-Products, Inc. headquarters.

JK Products, Inc. obligations do not include transportation charged on the shipping of new components to the customer or on the return of de-

fective components of the manufacturer. All freight charges must be paid by the customer.

There are no warranties which extend beyond the description on the face hereof. There is no express or implied warranty of fitness or merchantability.

The remedies provided in this limited warranty are the exclusive remedies provided to the purchaser by Global Service USA and are provided in substitution of all other remedies. Consequential and incidental damages are excluded.



NOTE:

Any misuse, abuse, modification, alteration, improper maintenance, improper installation, etc. of this product or its intended use will subject said party to direct responsibility and liabilities for any and all consequences resulting from such action. Furthermore, such actions will void all warranties and may relieve Global Service USA of any liabilities relating to said product.



NO POSTAGE
NECESSARY
IF MAILED
IN THE
UNITED STATES

BUSINESS REPLY MAIL
FIRST-CLASS MAIL PERMIT NO 295 JONESBORO AR

POSTAGE WILL BE PAID BY THE ADDRESSEE

JK PRODUCTS & SERVICES, INC.
#1 WALTER KRATZ DRIVE
JONESBORO, AR 72401

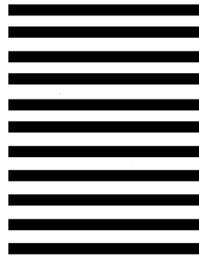

Separate here



SUN | **DASH**
PERFORMANCE | TANNING

soltron

Ergoline

Ⓐ WARRANTY REGISTRATION

Please complete the warranty section below. To validate and insure proper coverage, card must be completed and returned within ten (10) days of the date of purchase.

_____/_____/_____
Name of Purchaser Date of Purchase

Street Address or P. O. Box

City State Zip

()

Phone Number with area code

Company unit purchased from and amount paid.

Name of Business (if applicable)

E-mail

Circle Answers:

Type of Business:

Tanning Salon Video Store Health Club Beauty Salon

Other _____

Number of tanning beds at this location:

1-3 4-7 8-15 16-25 >25

If you experience any difficulties obtaining replacement parts from your distributor, please call Sun Ergoline at 800-643-0086, choose option 5.

Year & Model #

Serial #

SUN ERGOLINE, A DIVISION OF JK-PRODUCTS & SERVICES, INC.

2905 Northwest Blvd., Suite 40 · Plymouth, MN 55441, USA

E-Mail: ergoline@sunergoline.com · Fax: 763.551.3607

Phone: 888.771.0996 · Website: www.sunergoline.com

Ergoline

1003519